

UK SCAN 5004 FRL

UK - ASSEMBLY AND INSTRUCTIONS MANUAL
SCAN 5004 FRL



SCAN®

ASSEMBLY AND INSTRUCTION MANUAL SCAN 5004 FRL

CONGRATULATIONS ON YOUR NEW SCAN BUILT-IN STOVE

You have purchased a product by one of Europe's leading manufacturers of wood-burning stoves, and we are sure that you will have years of pleasure from your purchase.

To make the best possible use of your stove, it is important that you follow our advice and instructions. Read through this Assembly and Instruction Manual carefully before you start to assemble your stove.

SCAN 5004 FRL

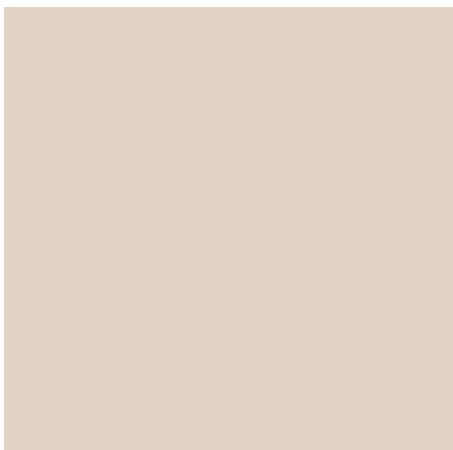
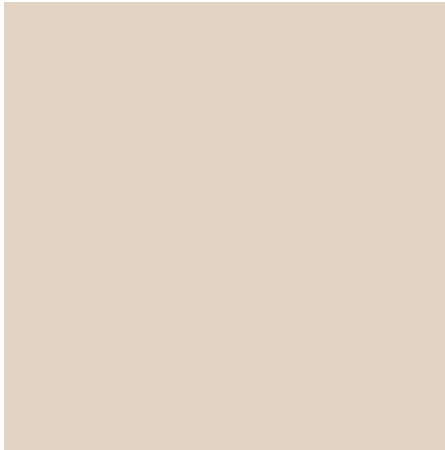

CONTENTS

■ TECHNICAL DATA			4
Installation	4	Dimension sketch Scan 5004 FRL	6
Safety	4	Type plate	7
Technical data and dimensions	5	Product registration number	7
■ ASSEMBLY			8
Additional accessories	8	Before building the insert	11
Disposal of packaging	8	Fresh air intake	12
Load-bearing foundation	8	Closed combustion system	12
Floor plate	8	Fresh air box	12
Existing chimney and pre-fabricated element chimney	8	Door (Self-closing)	13
Connection between built-in stove and steel chimney	8	Clips for Norway (Large rooms)	14
Requirements for chimney	9	Heat-storage system	14
Trim	9	Mounting of the heat shields/convection covers	15
Internal installation in non-flammable material	9	Frames	18
Minimum distance to flammable materials	9	Braces	21
Building in the stove at a fire wall	9	Convection air	25
Safety distance	9	Mounting of convection grate	25
Building into flammable material with fire wall	10		
■ INSTRUCTIONS FOR USE			26
Baffle plates	26	Combustion air	26
■ INSTRUCTIONS FOR HEATING			27
Environmentally friendly operation	27	Firing in the spring or autumn	28
Lighting	27	General notes	28
Using the stove in various weather conditions	27	The function of the chimney	28
Continuous operation	28	Chimney fire	28
Warning about over-firing	28		
■ HANDLING OF THE FUEL			29
Selecting wood/fuel	29	Moisture	29
Preparation	29	Use of the following as fuel is illegal	29
Storing	29	Calorific value of the wood	29
■ MAINTENANCE			30
Sweeping the chimney and cleaning the stove	30	Gaskets	31
Checking the stove	30	Painted surfaces	31
Servicing	30	Disposal of stove parts	32
Combustion chamber lining	30	Cleaning the glass	32
■ TROUBLESHOOTING			34
■ WARRANTY			35

TECHNICAL DATA

INSTALLATION

- The house owner is responsible for ensuring that installation and assembly are in accordance with national and local building regulations as well as the information provided in this Assembly and Instructions Manual.
- When you install any kind of fireplace or stove, you must inform the local building and housing authorities. In addition you are obliged to have the installation inspected and approved by a local chimney sweep prior to commissioning.
- To ensure best-possible functionality and safety for your installation, we advise you to call a professional fitter. Your Scan dealer will be able to recommend a qualified fitter in your area. For information on Scan Dealers, please go to www.scan.dk.

SAFETY

Any changes made to the product by the dealer, fitter or user could result in the product and safety functions not functioning as intended. The same applies to the fitting of accessories or extra equipment not supplied by Scan A/S. This could also be the case if parts that are necessary for the operation and safety of the stove are dismantled or removed.



■ **PLEASE NOTE!**

YOU GET THE BEST USE OF
THE STOVE BY USING
A TOP-DOWN
LIGHTING METHOD

SEE
"INSTRUCTIONS FOR HEATING"



TECHNICAL DATA AND DIMENSIONS

Materials	Steel plate Cast iron Galvanised sheet Chamotte
Surface treatment	Senotherm
Max. log length	40 cm
Weight Scan 5004 FRL	210 kg
Weight Scan 5004 FRL w/heat shield	218 kg
Flue conn. piece internal diameter	175 mm
Flue conn. piece external diameter	200 mm
Approval type	Intermittend*

* Intermittent operation in this context means normal use of a built-in stove. In other words, you should let the fire die down until only the embers are left before refuelling.

This built-in stove is produced in accordance with type approval for the product, which also covers the product's Assembly and Instruction Manual.

The Declaration of Performance (DoP) is available from www.scan.dk

Test in compliance with EN 13229		
CO Emission at 13% O ₂	0,09	%
CO Emission at 13% O ₂	1173	mg/Nm ³
Dust @ 13% O ₂	25	mg/Nm ³
No _x @ 13% O ₂	81	mg/Nm ³
Efficiency	83	%
Energy efficiency index	111,2	
Energy efficiency class	A+	
Nominal output	7,8	kW
Chimney temperature EN 13229	221	°C
Temperature in flue conn. piece	265	°C
Amount of smoke	6,9	g/sek
Sub-pressure EN 13229	12	Pa
Recommended sub-pressure in connecting piece	16-20	Pa
Required combustion air supply	20-35	m ³ /h
Fuel	Wood	
Fuel consumption	2,2	kg/h
Amount of fuel required to light	1,9	kg
Amount of fuel, max.	3,25	kg

DIMENSION SKETCH SCAN 5004 FRL

- A** Height to the beginning of flue connecting piece at top outlet
- B** Centre of fresh air intake - Inside measure: 132 mm, Outside measure: 149 mm
- C** Flue conn. piece - Inside measure: 175 mm, Outside measure: 200 mm

All measures are in mm

*NB - remember to check the distance to flammable materials.

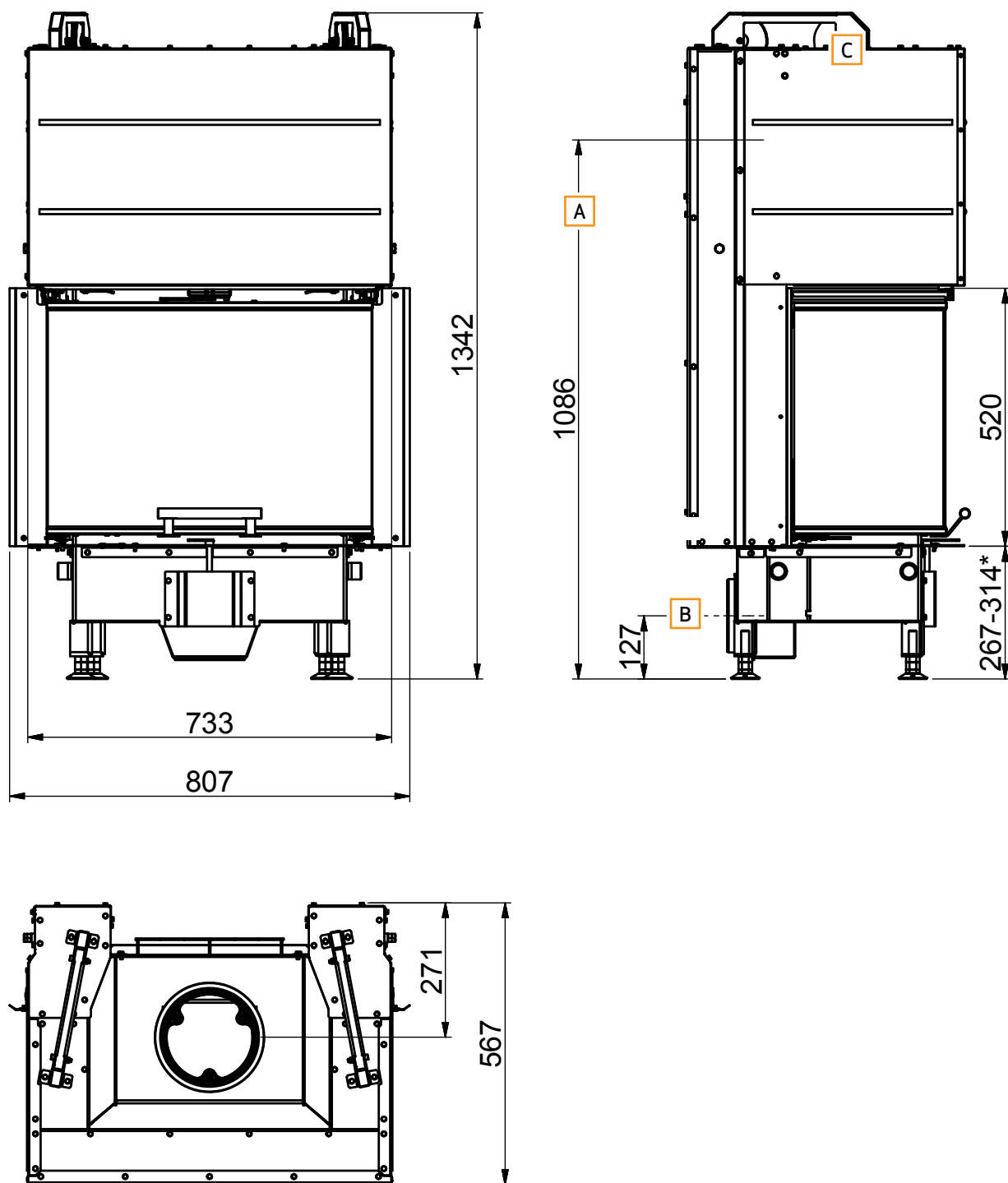

TYPE PLATE

All Scan built-in stoves are fitted with a type plate that specifies the approval standards and the distance to flammable materials. The type plate is placed loose in the fireplace.

Type plate Scan 5004 FRL

Scan 5004 FRL			
Freestanding room heater fired by solid fuel			
Standard:	EN 13229	DoP 95004600	
Minimum distance to combustible materials Side: 400 mm - Back: 400 mm - Front: 800 mm			
Minimum distance to firewall See assembly- and instructions manual			
The appliance can be operated in a shared flue.			
CO emission at 13% O ₂ :	0,09%	1173 mg/Nm ³	
Dust at 13% O ₂ :		25 mg/Nm ³	
Flue gas temperature:		221°C	
Nominal heat output:		7,8 kW	
Efficiency:		82,9%	
Fuel type:		Wood	
Operation type:		Intermittent	
Reaction to fire:		A1	
Country	Classification	Certificate/Standard	Approved by
EUR	Intermittent	EN 13229	SZU
Norway		NS 3058	Teknologisk Institut
Germany	Stufe 2	1. BlmSchV	
Follow assembly- and instructions manual. Use only recommended fuels. Montage- und Bedienungsanleitung beachten. Verwenden Sie nur empfohlene Brennstoffe.			
1000	Scan A/S	DK 5492 Vissenbjerg	08-2017

PRODUCT REGISTRATIONNUMBER

All Scan built-in stoves are provided with a product registration number. Please make a note of this number at the rear page of this manual; you will always need to quote it when contacting your dealer or Scan A/S.

The product registration number is placed loose in the fireplace.

Product registration number Scan 5004 FRL

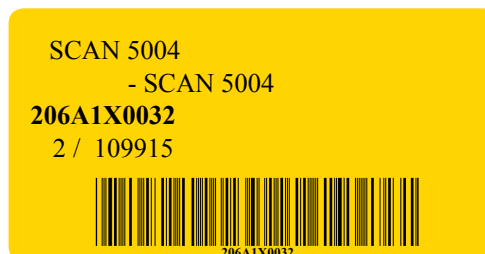

ASSEMBLY

ADDITIONAL ACCESSORIES

- Fresh air box Ø149 cm (see page 12)
- Heat shields/convection covers (see page 15)
- Braces with frames (see page 21)
- Heat-storage stones (see page 14)
- Frames (see page 18)
- Convection air grid (see page 25)

DISPOSAL OF PACKAGING

Your Scan built-in stove may come supplied with the following packaging:

Wood packaging	The wood packaging can be reused and after final use can be incinerated as a CO ₂ neutral product or sent for recycling.
Polystyrene top	Send for recycling or waste disposal.
Foam	Send for recycling or waste disposal.
Plastic bags	Send for recycling or waste disposal.
Stretch/plastic film	Send for recycling or waste disposal.

LOAD-BEARING FOUNDATION

All items in our product range come under the category of lightweight fireplaces and stoves and do not normally require any reinforcement of the beam structure. They can be positioned on ordinary beams/floor.

You should of course make sure that the foundation on which the stove is positioned can indeed support the weight of the stove and, where applicable, a steel chimney, if you have opted for this solution. In case of doubt about the carrying capacity of the floor, please consult a building expert.

FLOOR PLATE

If you are placing the stove on a flammable floor, you must comply with the national and local regulations on the size of any non-flammable subsurface required to cover the floor around the stove.

Your local Scan dealer can advise you on regulations concerning protection of flammable materials in the vicinity of your stove.

The floor plate's function is to protect the floor and flammable material against any sparks that may occur.

EXISTING CHIMNEY AND PRE-FABRICATED ELEMENT CHIMNEY

If you intend to connect your stove to an existing chimney, it makes sense to contact an authorised Scan dealer, or a local chimney sweep, for advice. These experts will also let you know if your chimney needs renovating.

- When connecting a pre-fabricated element chimney, follow the manufacturer's connection instructions for the relevant chimney type.

CONNECTION BETWEEN BUILT-IN STOVE AND STEEL CHIMNEY

Your Scan dealer, or local chimney sweep, can advise you on choosing a make and type of steel chimney. This ensures that the chimney will match your wood-burning stove.

REQUIREMENTS FOR CHIMNEY

The chimney must have a minimum internal diameter of 190 mm and have a T400 designation, with G for the soot fire test. The length must be min. 3,5 metres.

If you opt to connect the built-in stove with an elbow pipe, you should use a curved elbow, as this gives a better draught.

If you connect the stove with a sharp elbow pipe, the cleansing lid must be placed in the vertical part so that the horizontal part can be cleaned through here.

The requirements to the chimney and the flue pipe in terms of safety distances must be met.

- Choosing the wrong length or diameter of steel chimney could impair functionality
- Always comply exactly with the instructions provided by the steel chimney supplier

TRIM

The trim is mounted, when the surfaces of the covering are finished.

INTERNAL INSTALLATION IN NON-FLAMMABLE MATERIAL / EXISTING BRICKWORK

When building or fitting into structures that do not contain flammable materials, a minimum distance of 10 mm must be maintained between the brickwork and the convection hood. This is to prevent cracks in the brickwork caused by the expansion of the metal while the stove is heating. This construction does not require convection grates except for the convection air produced by the convection box of the insert. However, please note that without convection grates, the effect of the insert will be lower.

MINIMUM DISTANCE TO FLAMMABLE MATERIALS (WHICH IS NOT PROTECTED BY FIREWALL)

Distance to side: 400 mm - back: 400 mm - glass: 800 mm. - ceiling: 800 mm.

You should however assess whether furniture or other items might become excessively dry due to being too close to the stove.

- The stove is NOT to be built into flammable materials without the use of a fire wall and heat shields!

BUILDING IN THE STOVE AT A FIRE WALL



We refer to the building sketches on page 10.

SAFETY DISTANCE

European, national and local regulations concerning safety distances for wood-burning stoves and flue pipes must be complied with.

BUILDING INTO FLAMMABLE MATERIAL WITH FIRE WALL

Building in the Scan 5004 FRL with radiation shields against a flammable wall protected by a fire wall.

-  Flammable material
-  Fire wall, e.g. 50 mm Jøtul Firewall, 110 mm brick or other material with corresponding fireproof and insulating abilities

All distances are in mm.

All distances are minimum distances

Distance to furniture: 800 mm. from glass

* Distance to glass

** Distance to flammable floor

Installation with an insulated, vertical flue pipe

- structure/surround to ceiling

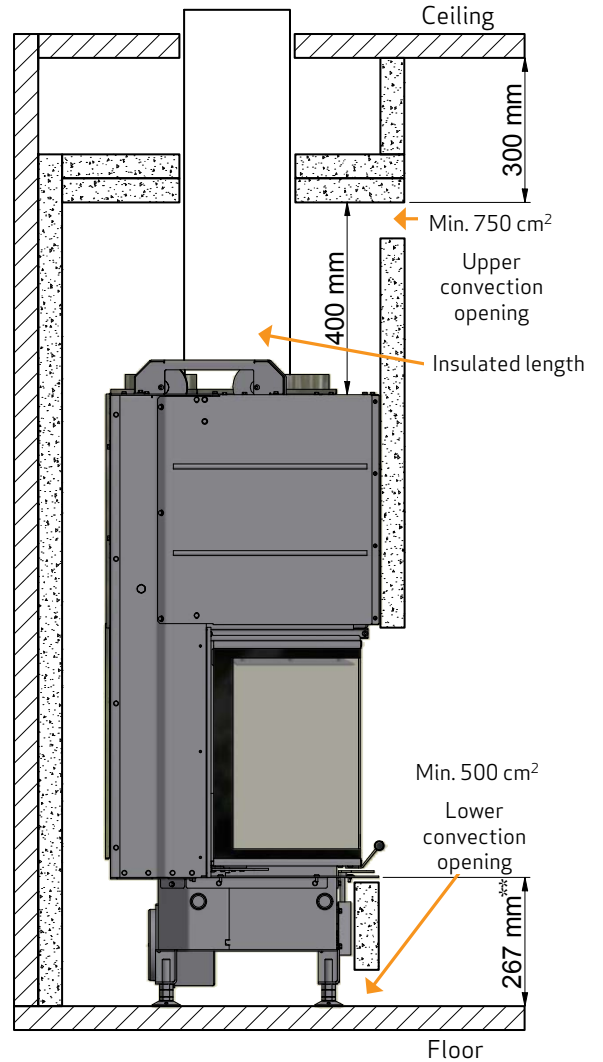

Installation with an insulated, vertical flue pipe

- open structure/surround

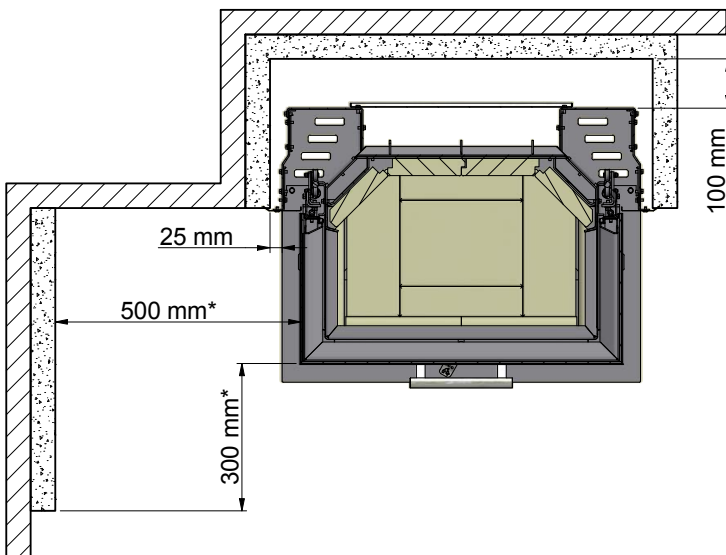
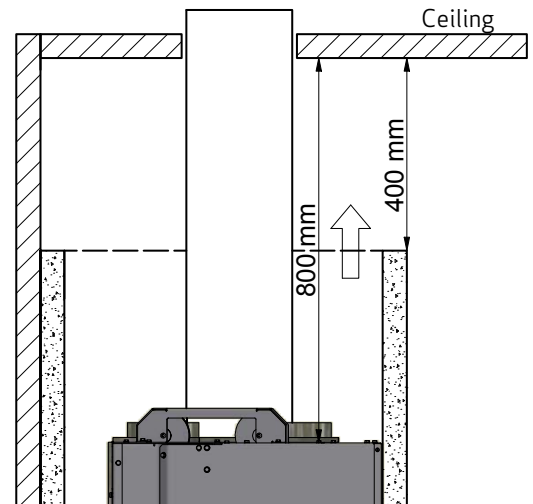

BUILDING INTO FLAMMABLE MATERIAL WITH FIRE WALL

The two cover plates in the front must be removed, when you build the stove into a flammable wall.

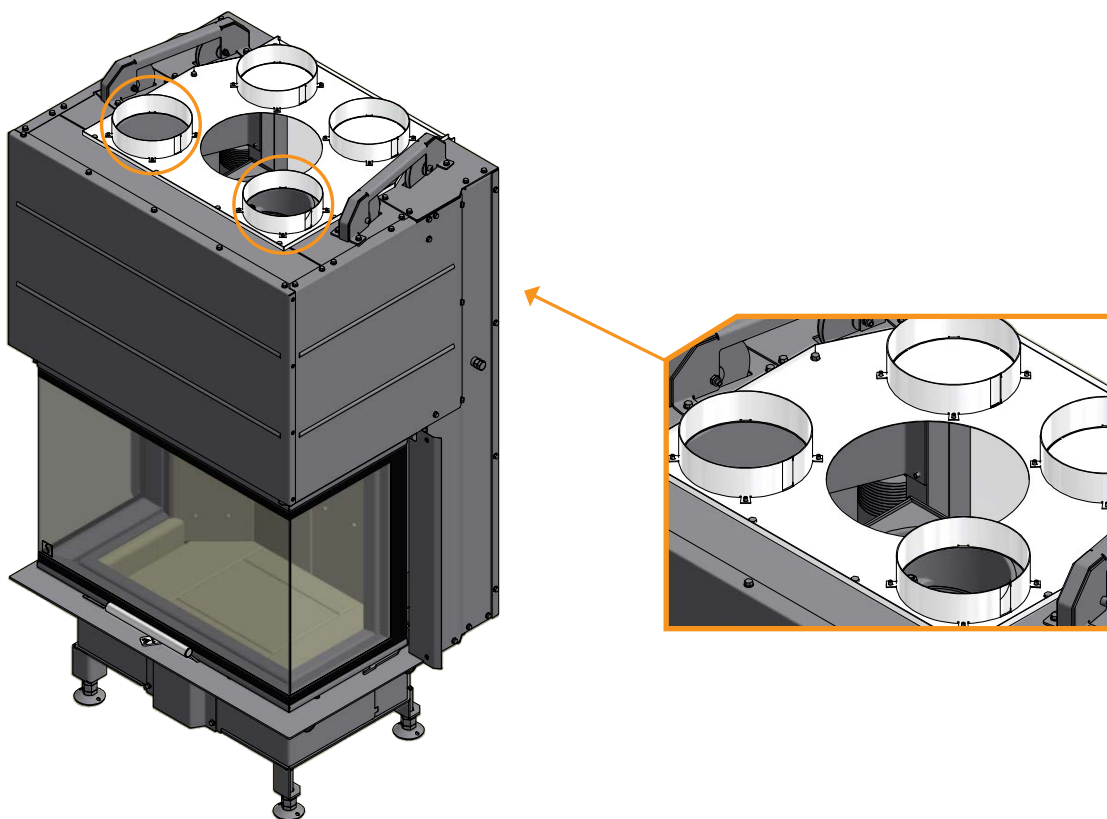

BEFORE BUILDING THE INSERT

IMPORTANT! Before the insert is built in, the bolts in each the side of the insert should be removed.

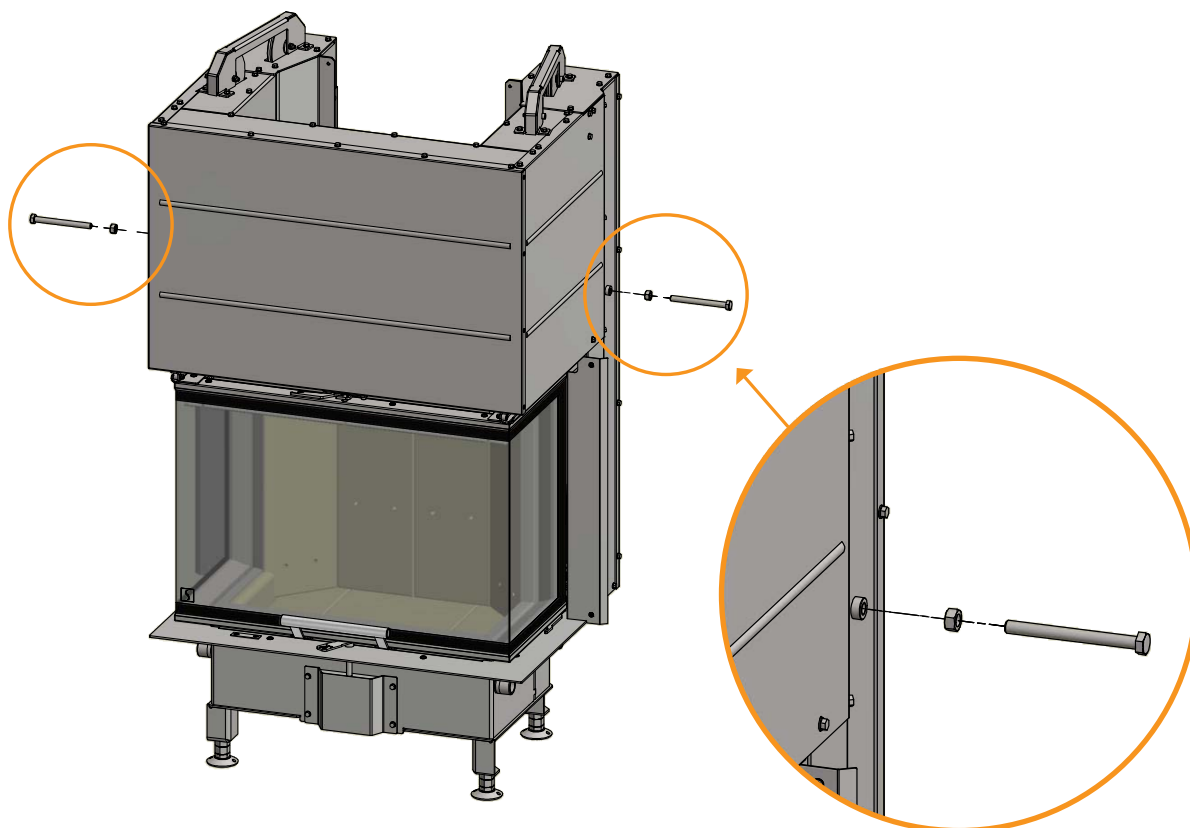

FRESH AIR INTAKE

In a well-insulated house the air used for the combustion process has to be replaced. This particularly applies to houses with mechanical ventilation. There are different ways of making sure that air is exchanged. The most important thing is to ensure that there is a supply of air to the room where the built-in stove is located. The external wall vent must be located as close to the stove as possible, and you must be able to close it when you are not using the stove.

National and local building regulations must be followed with regard to connection of a fresh air intake.

CLOSED COMBUSTION SYSTEM

You should use the closed combustion system for the built-in stove if you live in a newly-built, airtight home. External combustion air is connected through a ventilation pipe via the wall or floor.

We recommend mounting a valve in the ventilation pipe in order to avoid condensate in the stove and the pipe system, which can be closed when the oven is not in use. It can also be an advantage to insulate the ventilation pipe.

Minimum \varnothing 150 mm ventilation pipe, maximum length: 6 metres with a maximum of one bend. We recommend smooth steel pipes.

NOTE: If the stove has a fresh air connexion or closed combustion, the ventilation pipe must be open, when the stove is in use!

NOTE: If the combustion air is taken from a prefabricated chimney with integrated air vent, you must assure that there is a free area of min. 180 cm² between the inner core and the outer section.

FRESH AIR BOX (ACCESSORY)

A fresh air box is available as an accessory. For this box, you need a connection pipe (\varnothing 150 mm) which can be purchased in most D.I.Y.-stores.

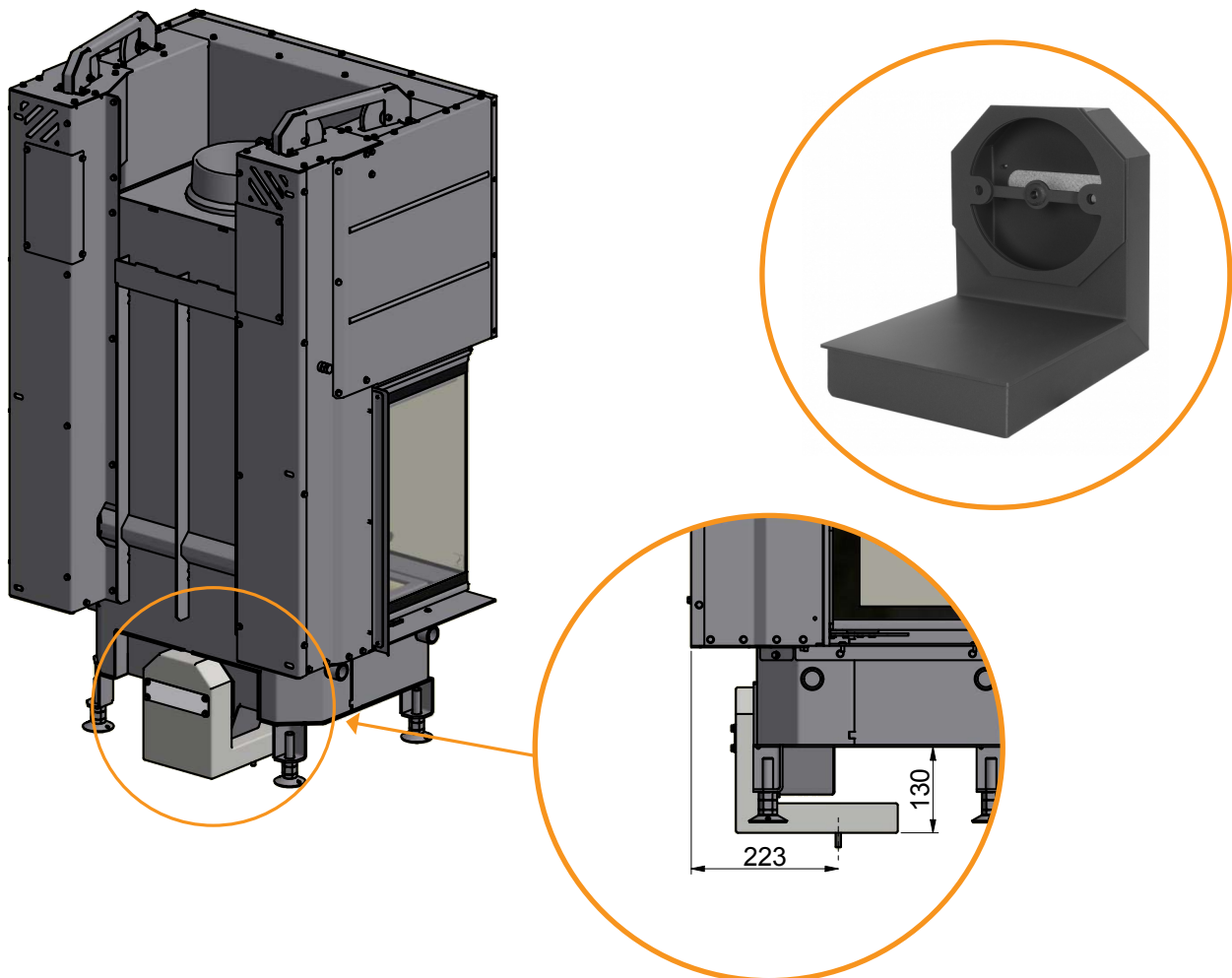

DOOR (SELF-CLOSING)

The door is delivered without self-closing function (Bauart 1). If you want a self-closing door, you can remove a disc from the counterweight.

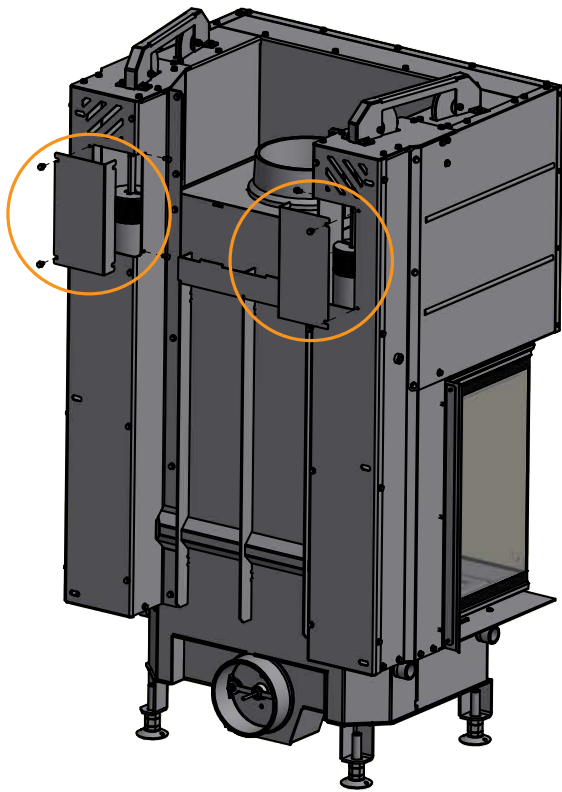

1

First remove the screws and the cover plates at the rear of the fireplace.

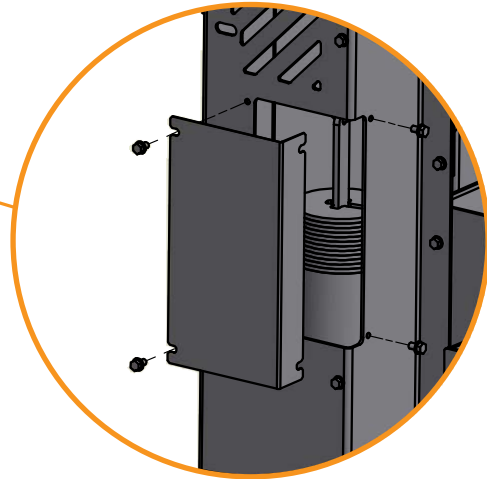

2

Remove the disc from the counterweight.

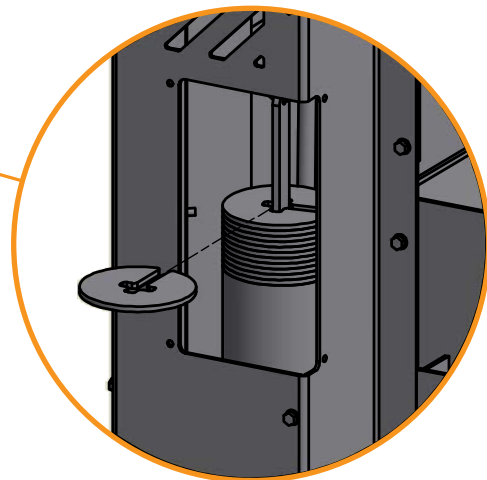
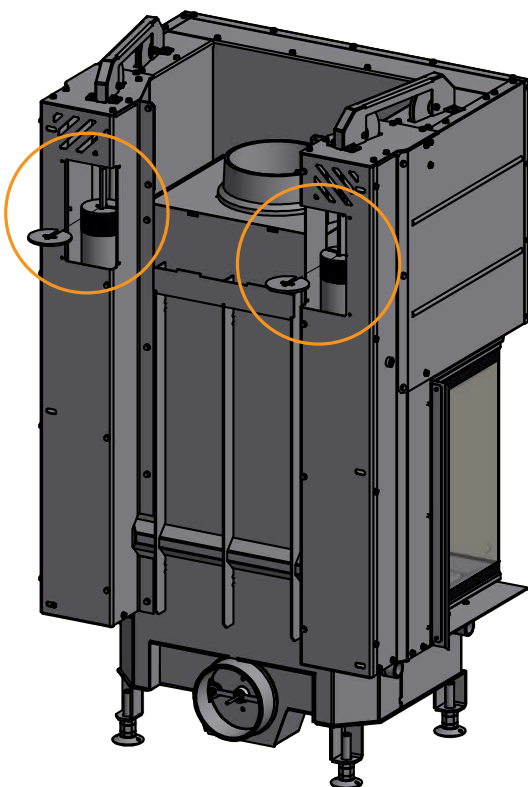

3

Remount the cover plates with the screws.

CLIPS FOR NORWAY (LARGE ROOMS)

NB: Norway only!

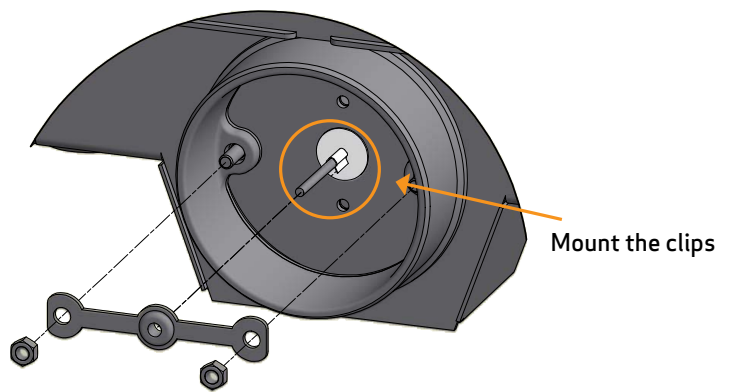
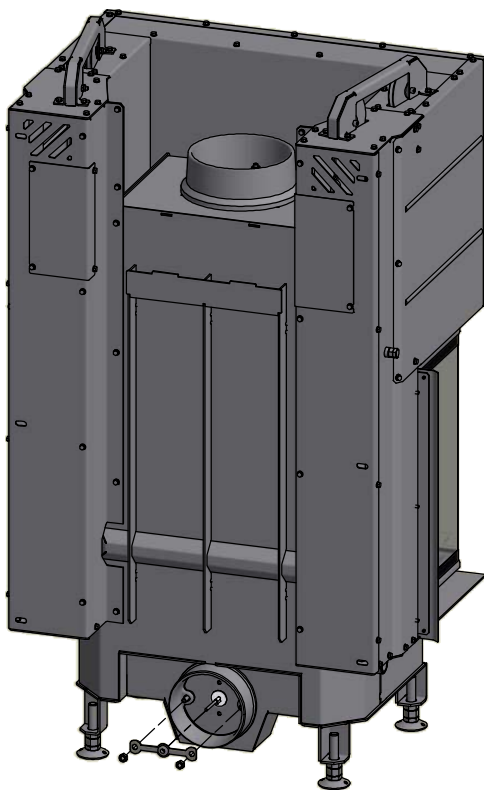

HEAT-STORAGE SYSTEM (ACCESSORY)

Heat-storage stones are made from a special material with a high heat capacity. The stones are heated when the stove is on, re-releasing heat once it is off. This extends the time over which the stove remains warm.

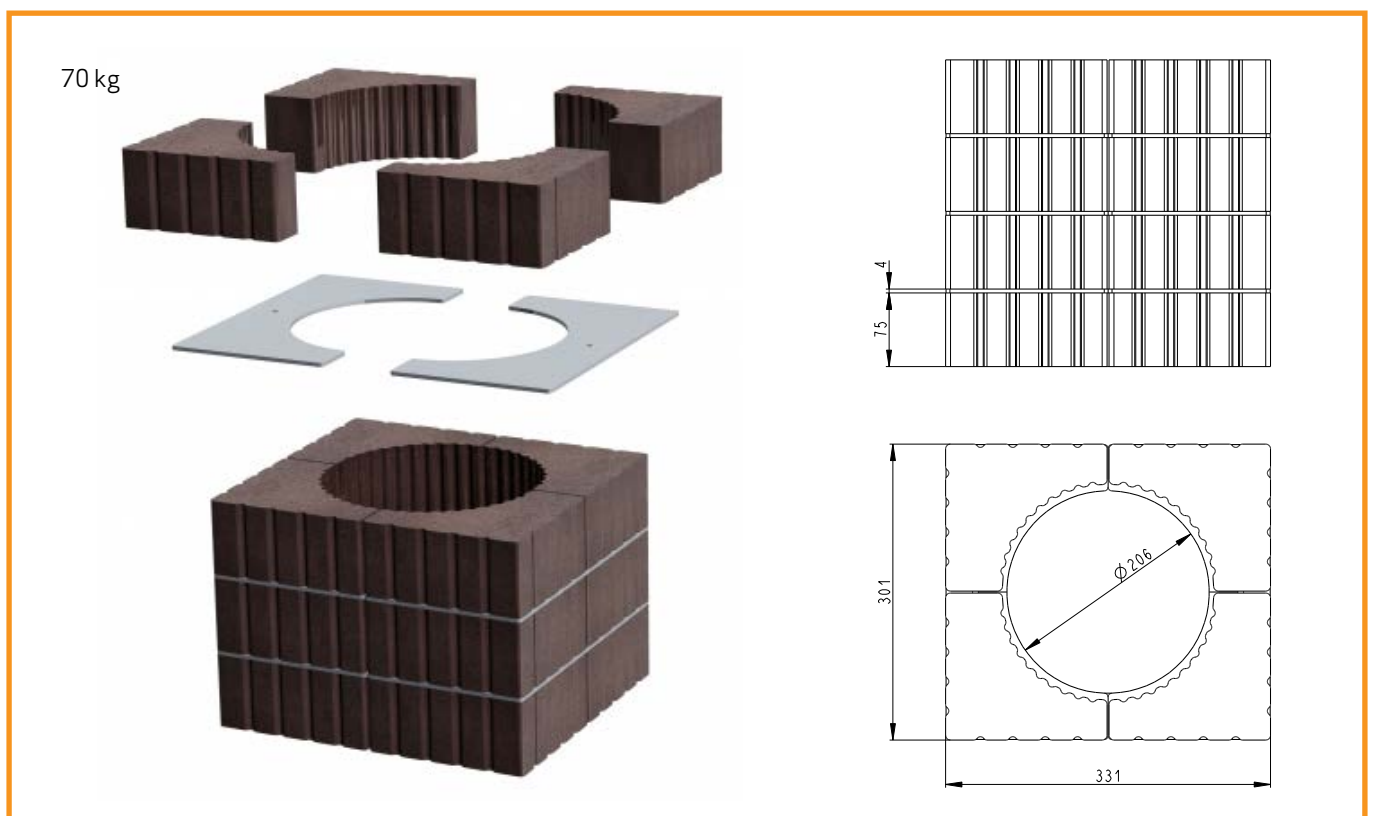

MOUNTING OF THE HEAT SHIELDS/CONVECTION COVERS (ACCESSORY)

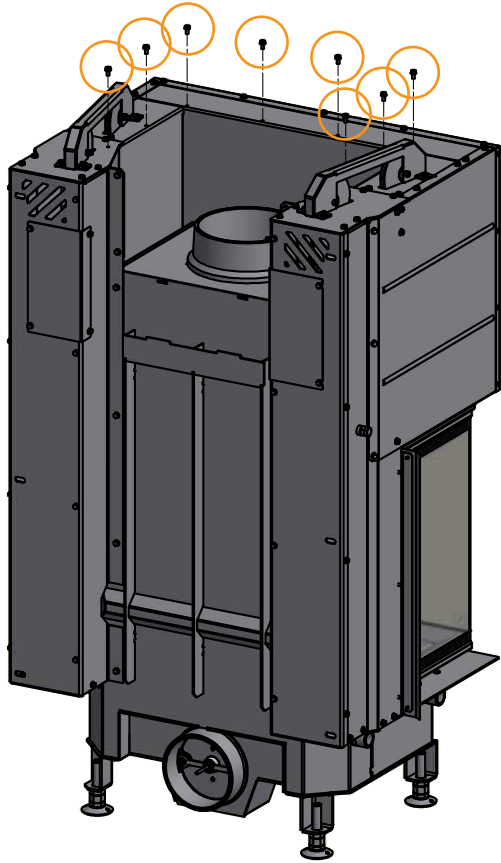

1

Dismount the screws on top of the fireplace

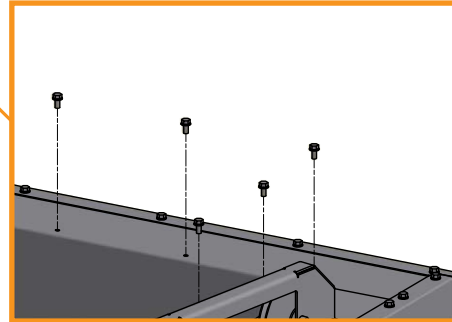

2

Place the heat shield on top of the stove and fasten it with the screws

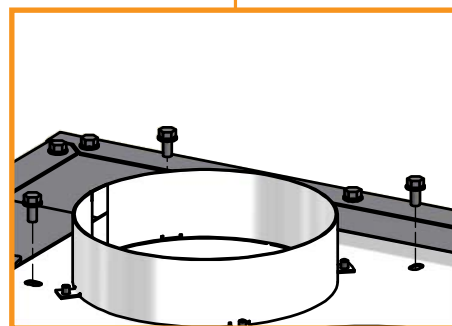
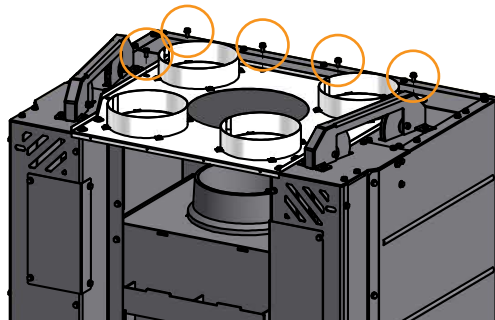
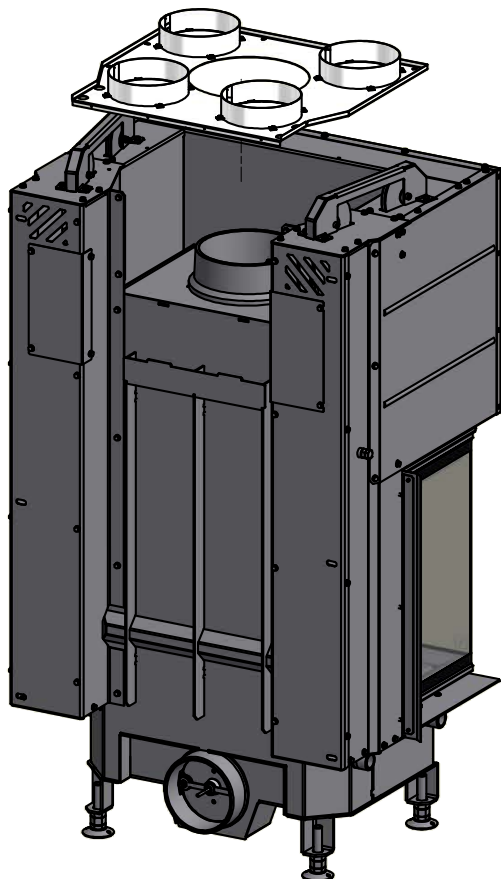

MOUNTING OF THE HEAT SHIELDS/CONVECTION COVERS (ACCESSORY)

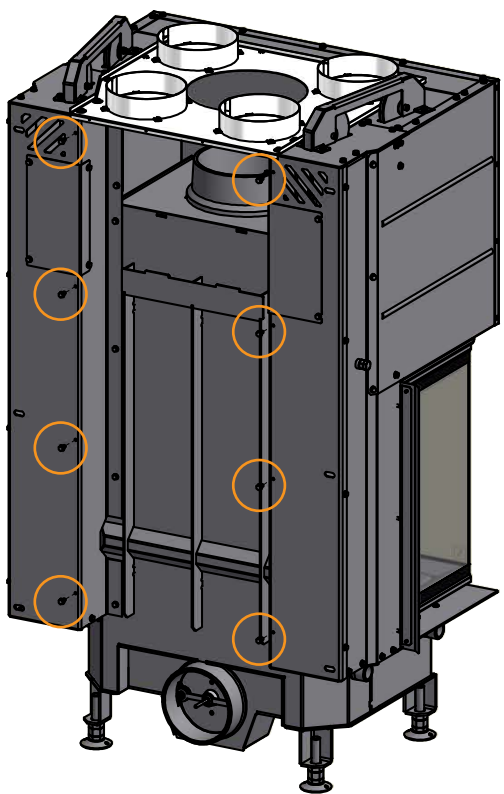

3

Dismount the screws at the rear of the stove

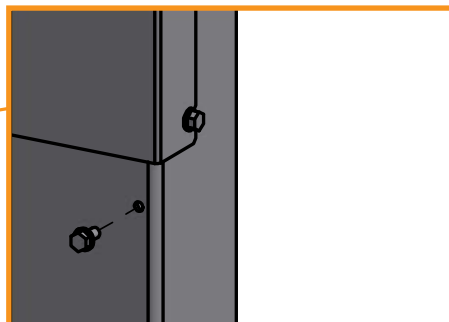

4

Place the metal plate #1 at the rear of the stove and fasten it with the screws

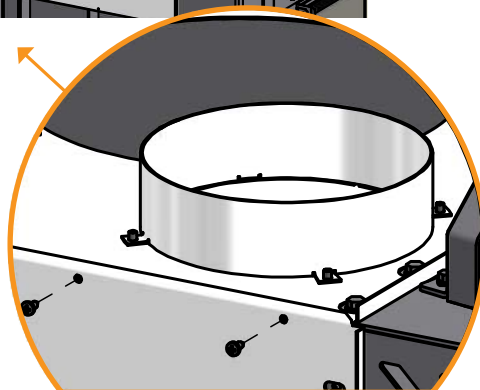
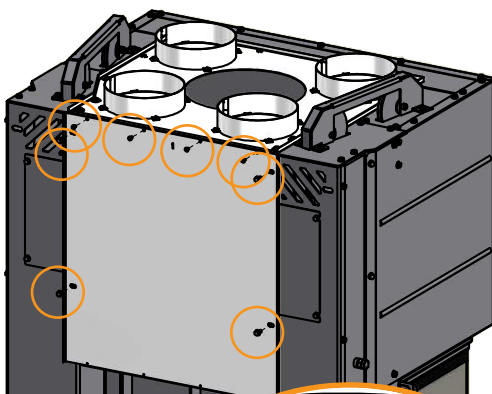
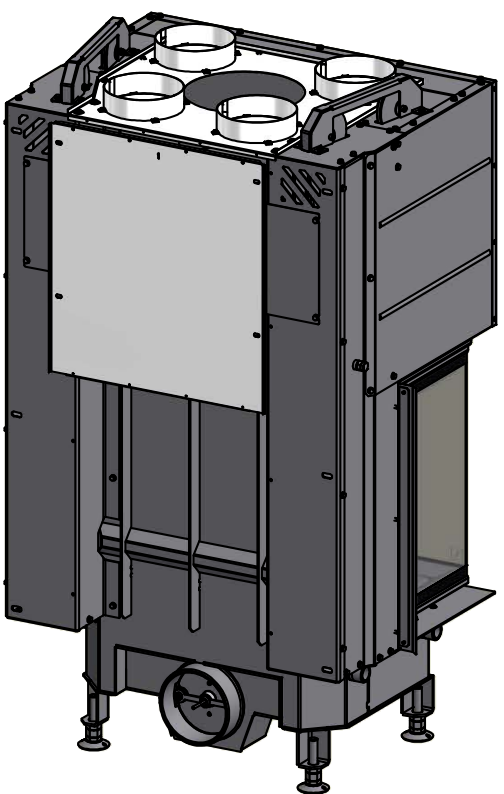

MOUNTING OF THE HEAT SHIELDS/CONVECTION COVERS (ACCESSORY)

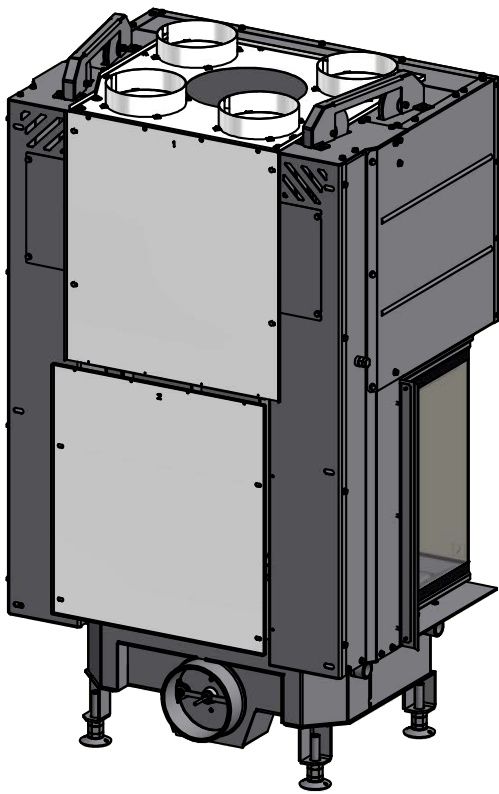

5

Place the metal plate #2 at the rear of the stove

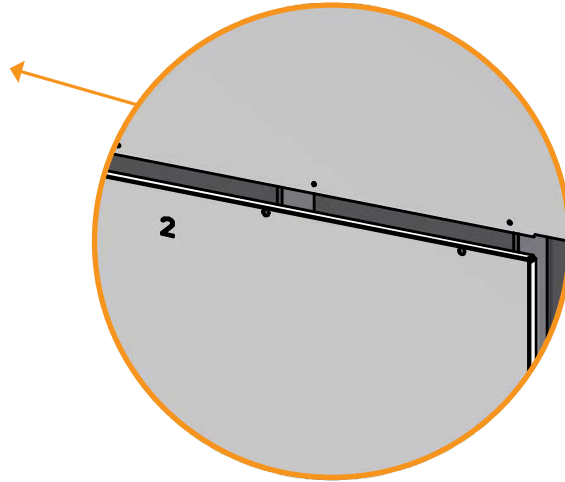

6

Fasten metal plate #2 with the screws

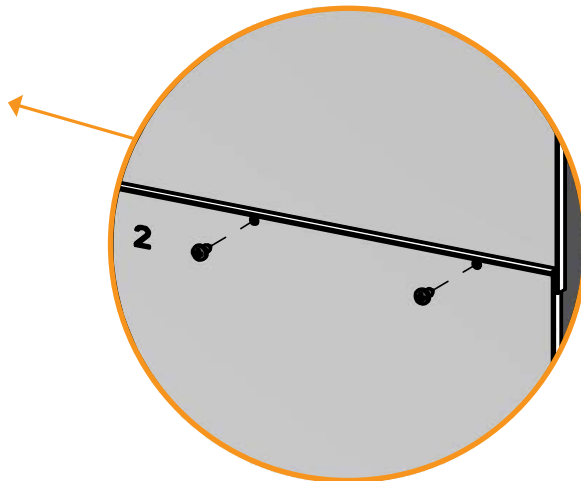
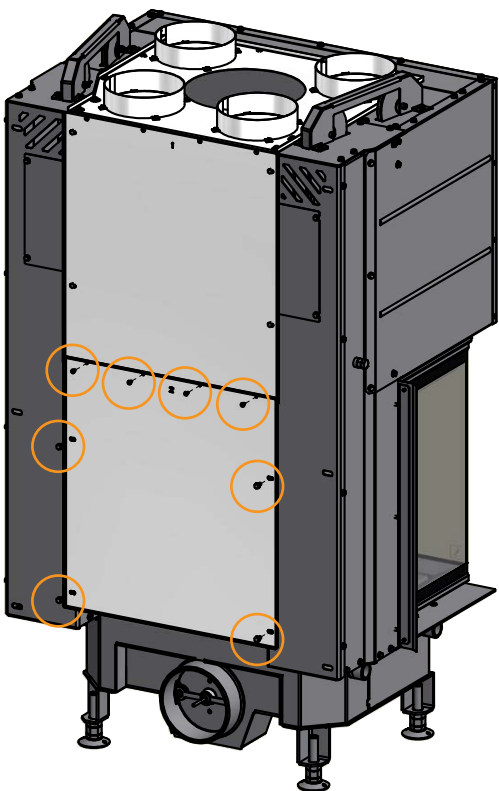

FRAMES (ACCESSORY)

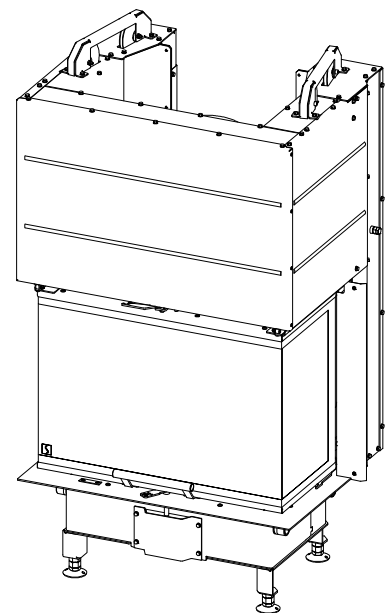
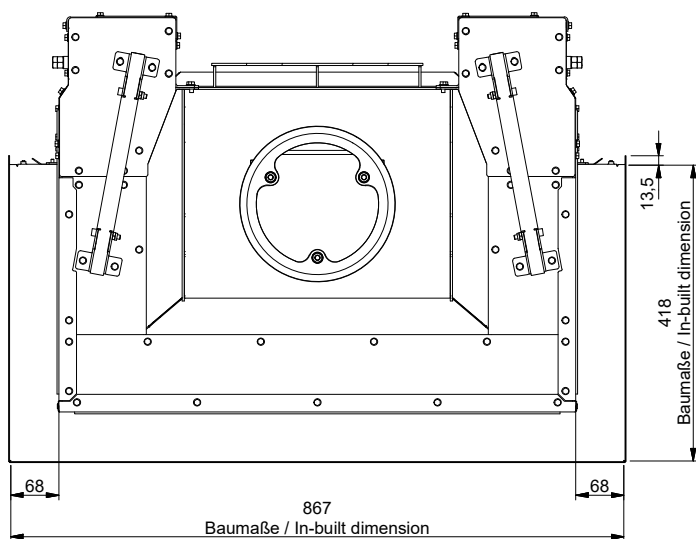
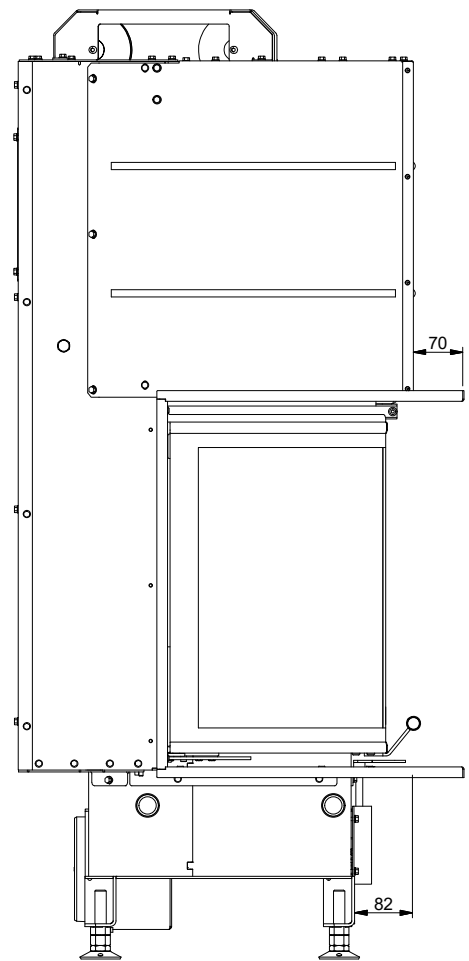
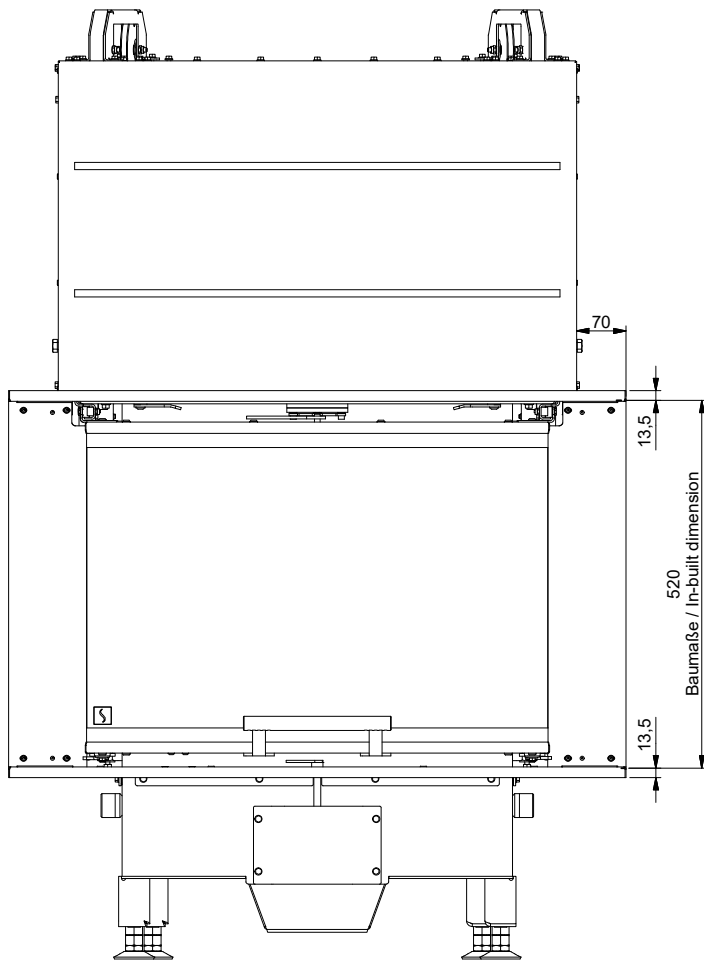

FRAMES (ACCESSORY)

Scan 5004 FRL Item nr. 50052628

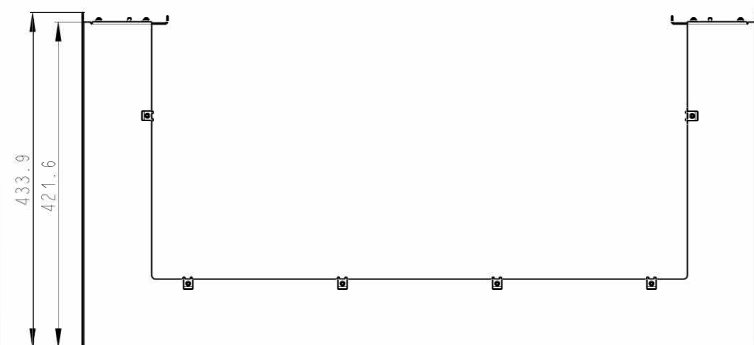
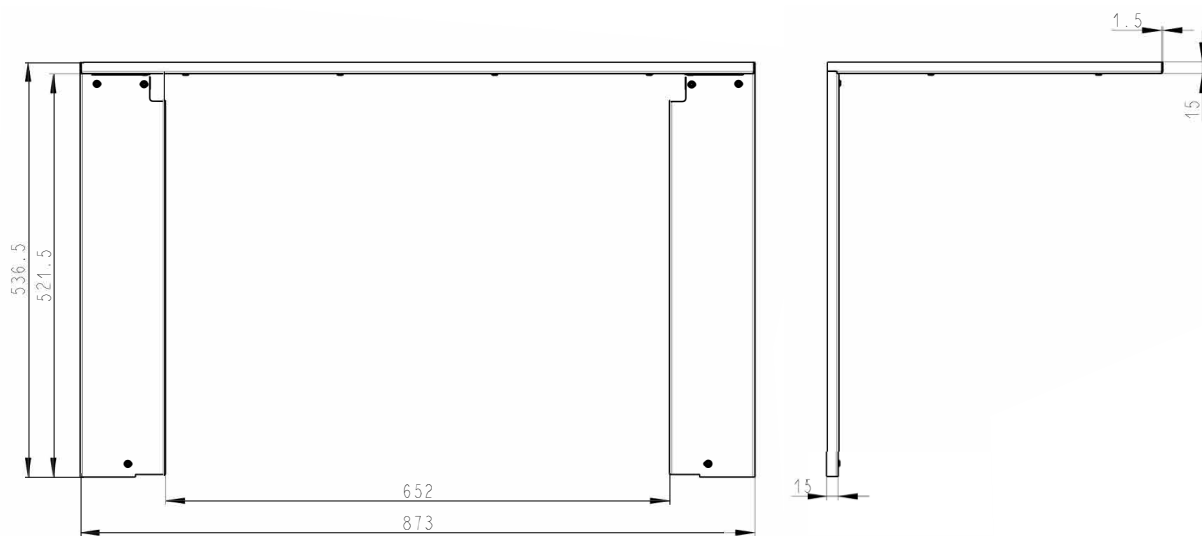
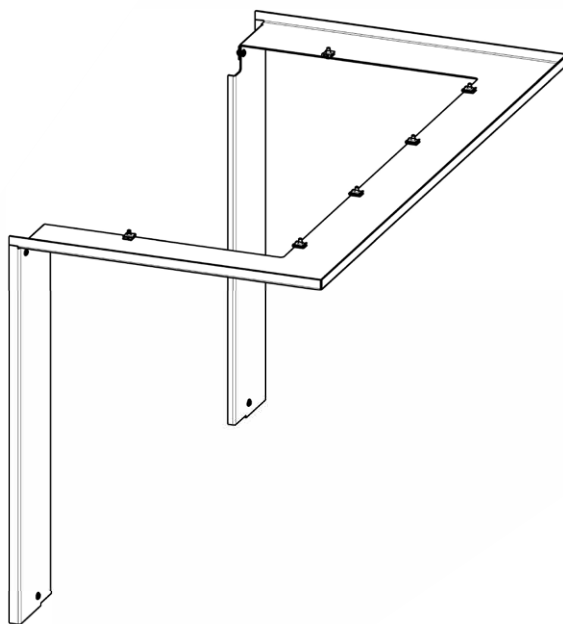

FRAMES (ACCESSORY)

Scan 5004 FRL Item nr. 50052629

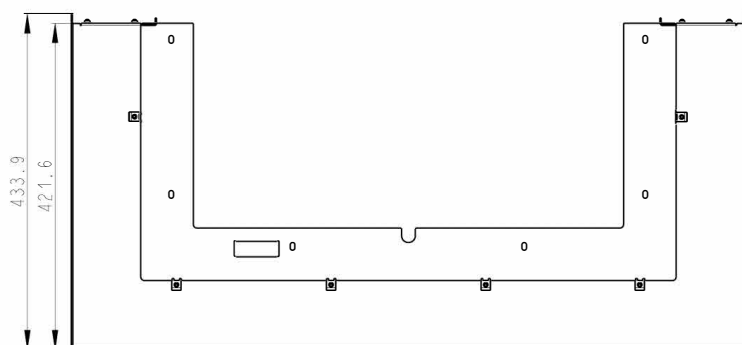
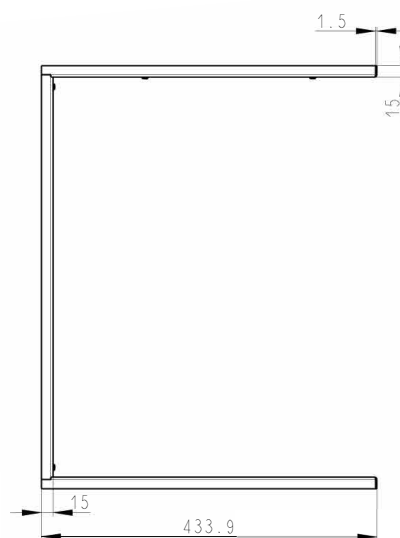
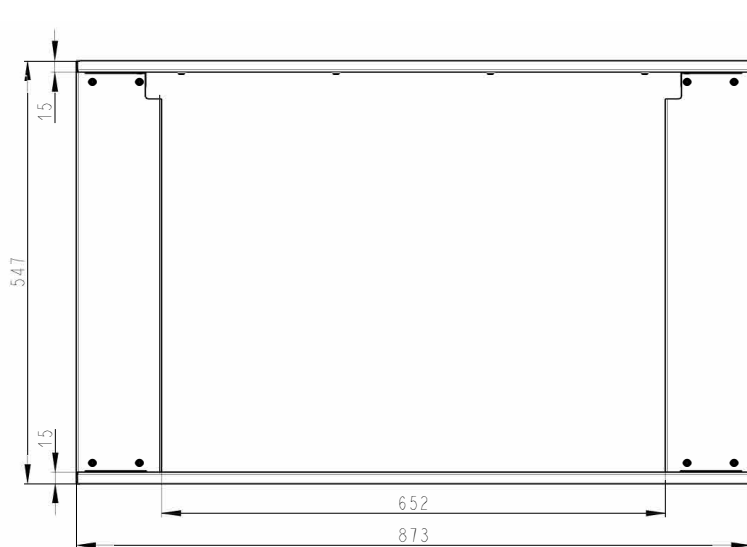
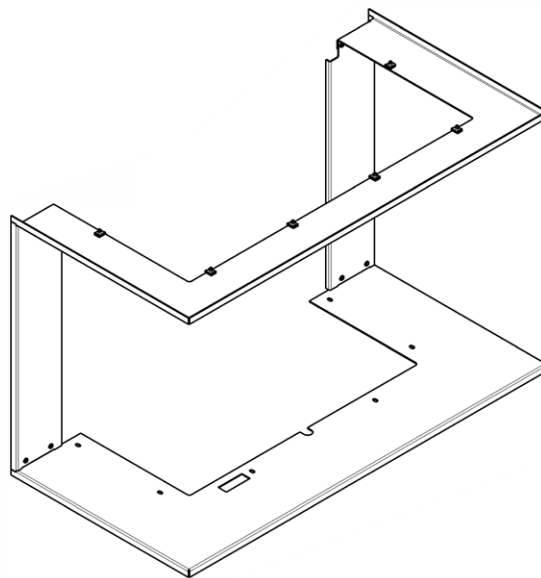

BRACES (ACCESSORY)

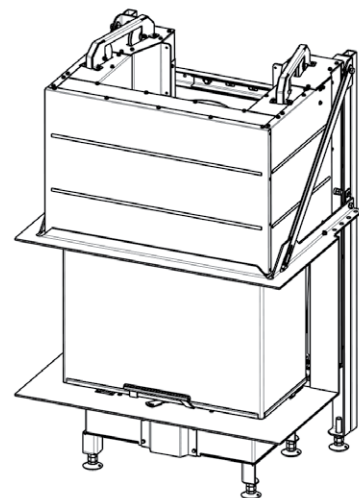
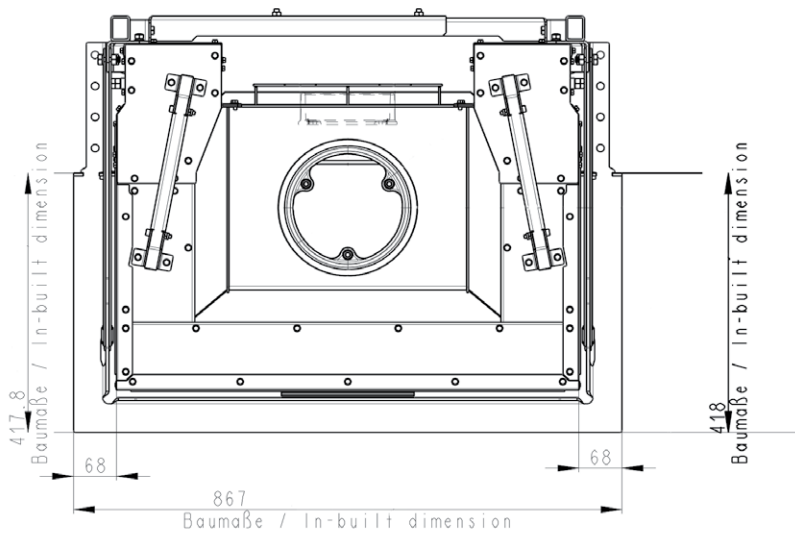
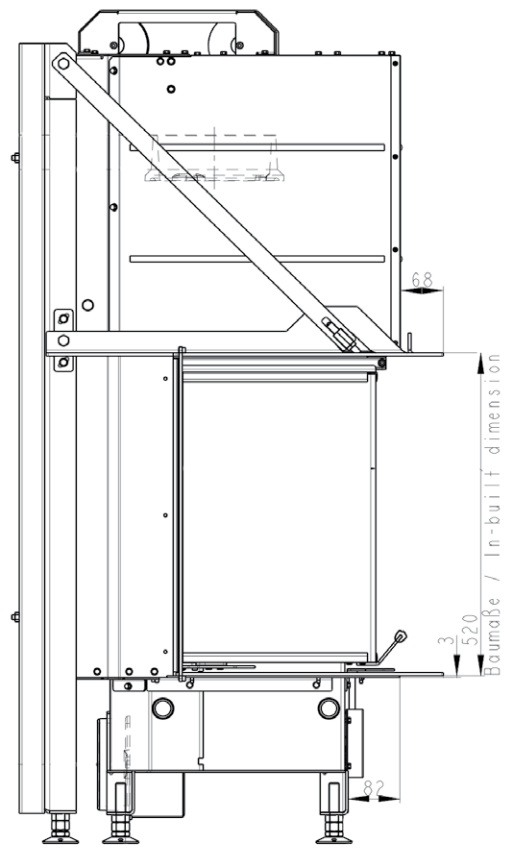
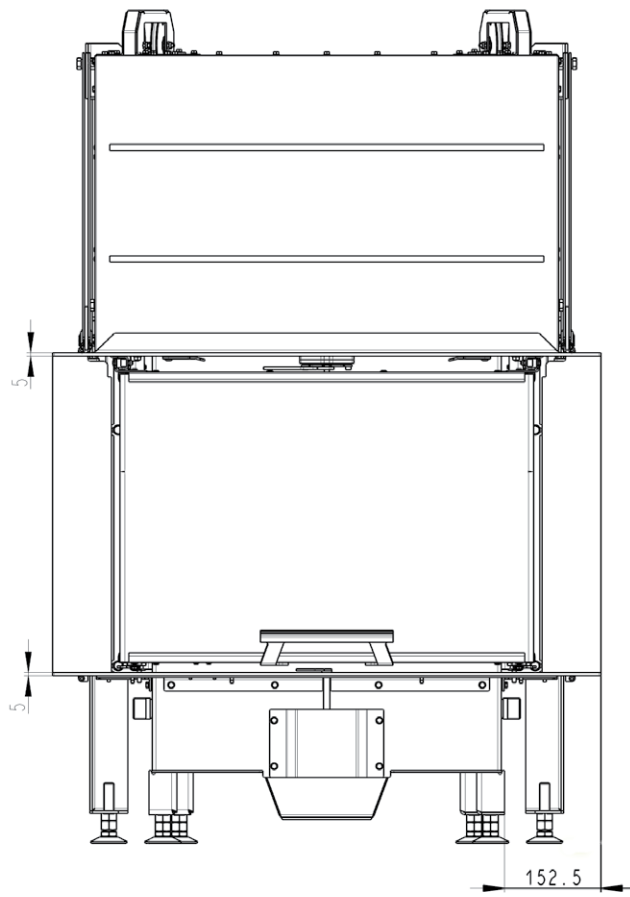

BRACES (ACCESSORY)

Scan 5004 FRL Item nr. 50052630

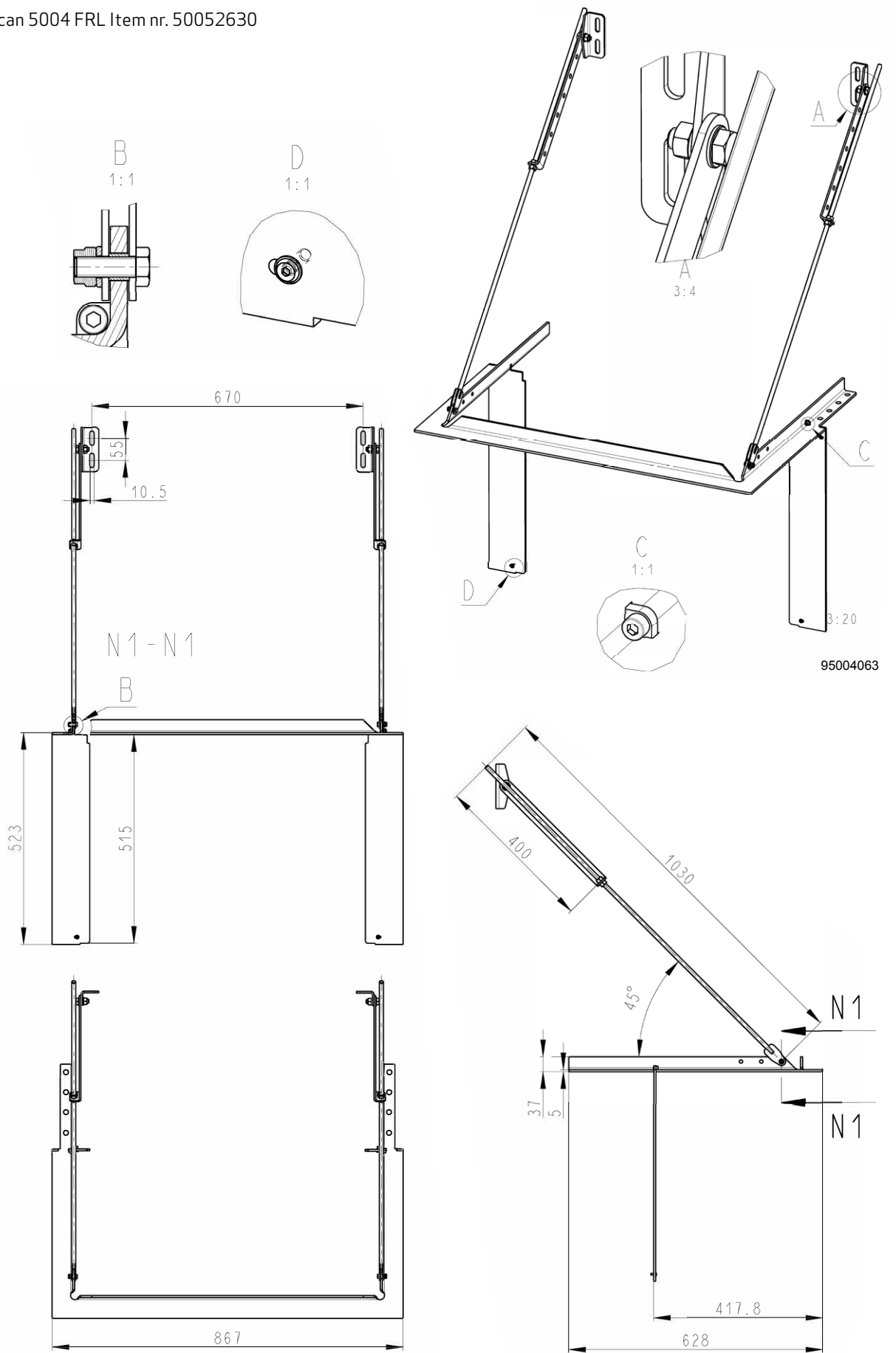

BRACES (ACCESSORY)

Scan 5004 FRL Item nr. 50052631

B
1:1

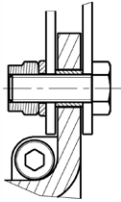

D
1:1

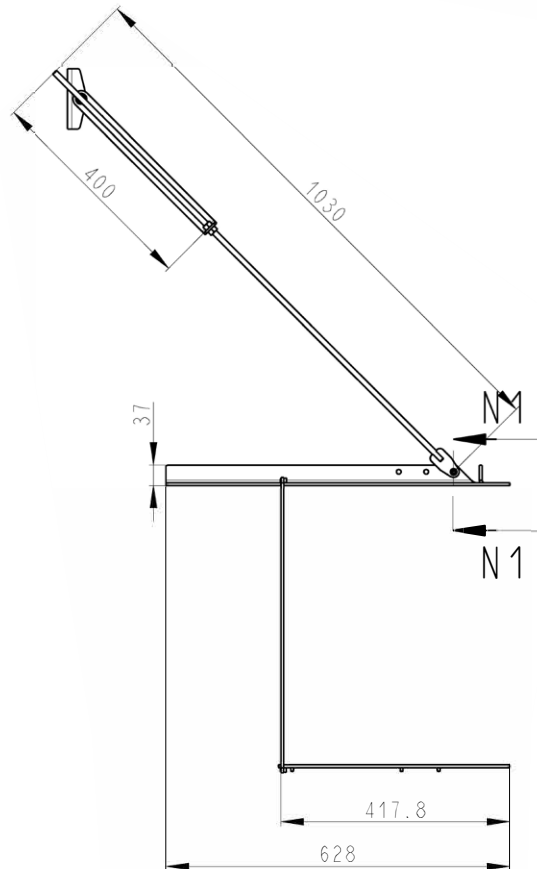
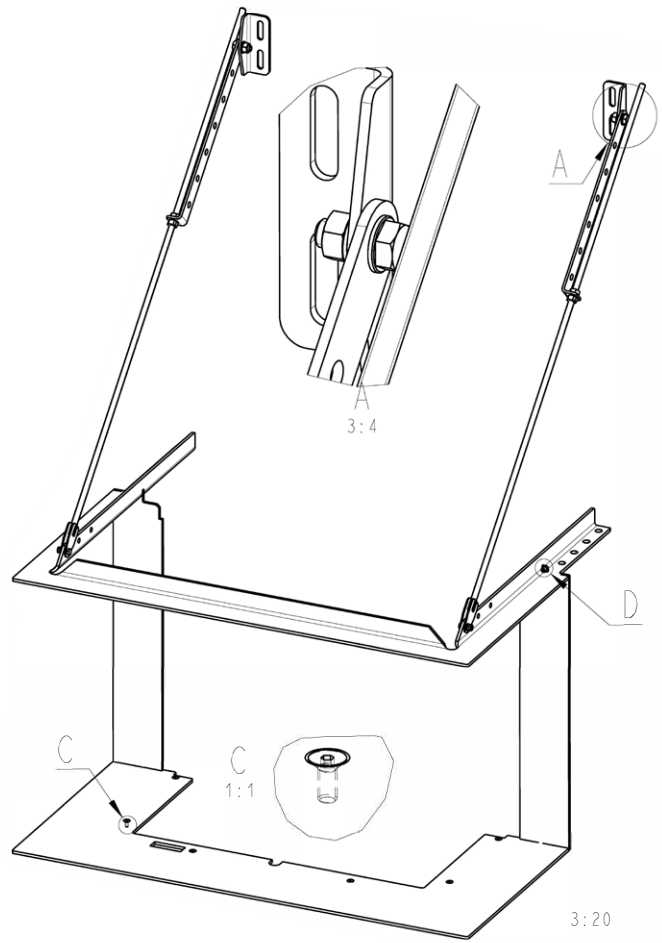
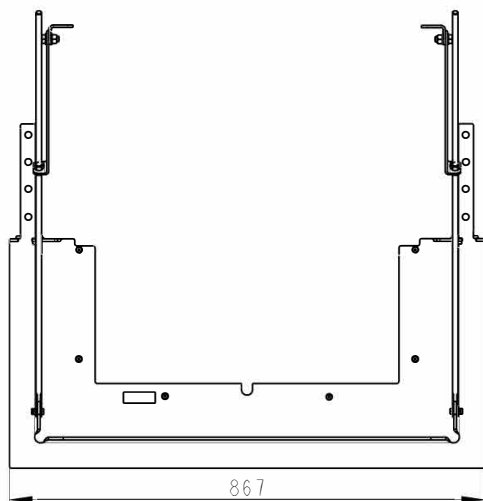
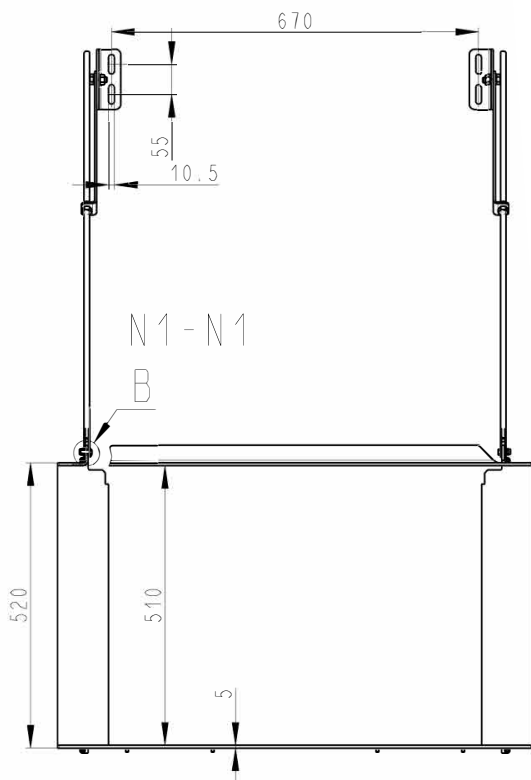
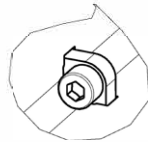

BRACES (ACCESSORY)

Scan 5004 FRL Item nr. 50052632

B
3:2

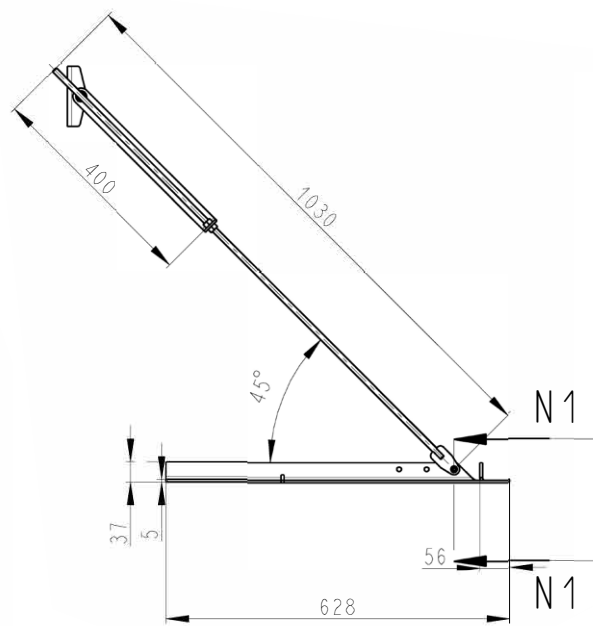
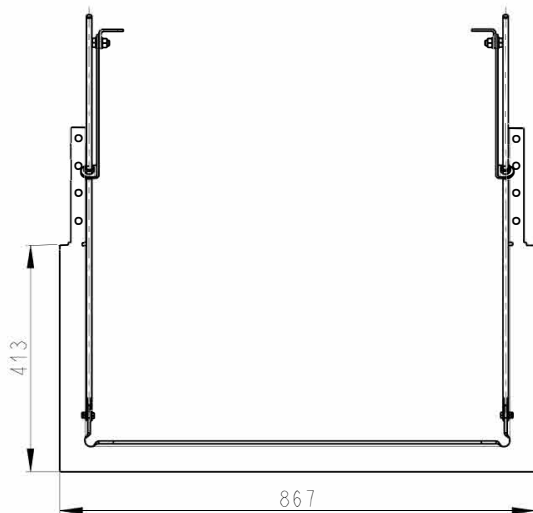
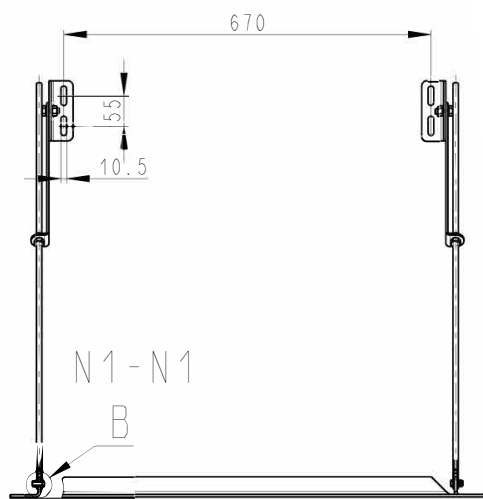
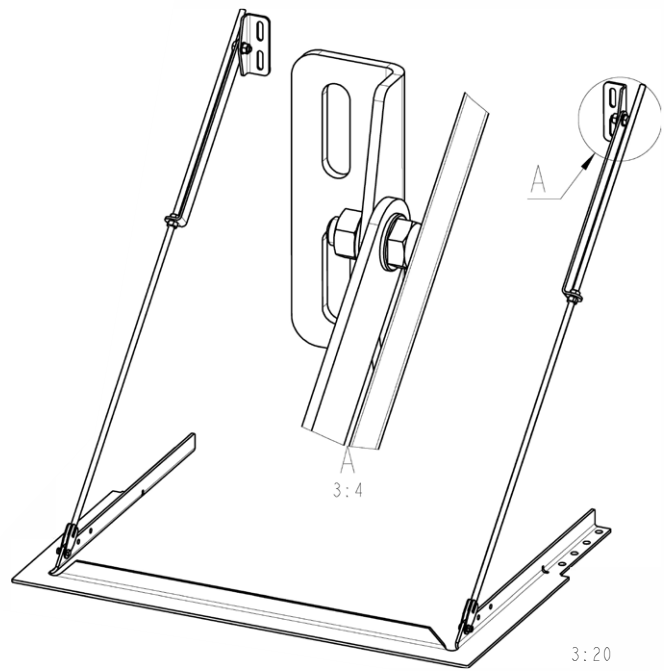
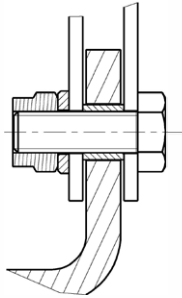

CONVECTION AIR

The covering must contain holes for convection air. Convection means that there is an air circulation ensuring that the heat is equally distributed in the room. It is important the demands concerning convection areas are observed.

■ Min. area for ingoing convection air: 500 cm²

■ Min. area for outgoing convection air: 750 cm²

If there is not enough convection air, the covering may be damaged.

Convection air grids are available as an accessory.

MOUNTING OF CONVECTION GRATE (ACCESSORY)

1

Cut a hole in the wall according to the indicated measures

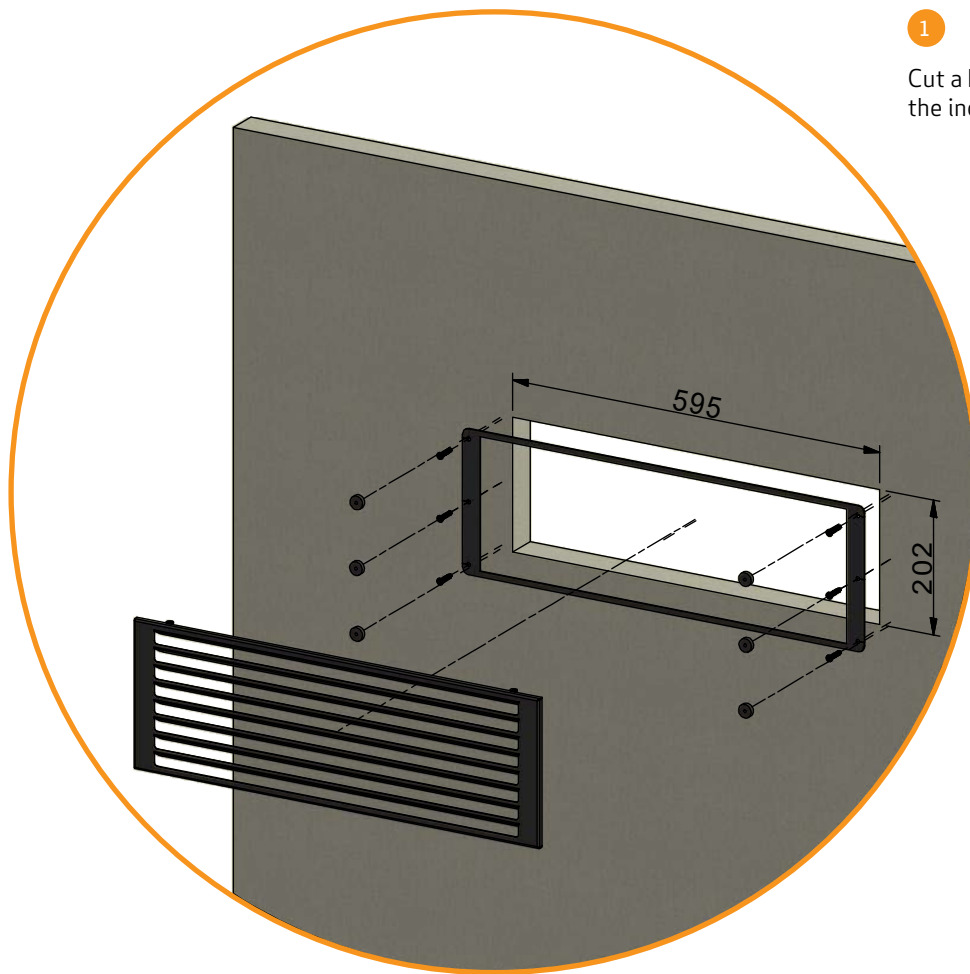

2

Fasten the metal frame with the six screws. Then mount the six magnets on the screws and place the convection grate on the magnets

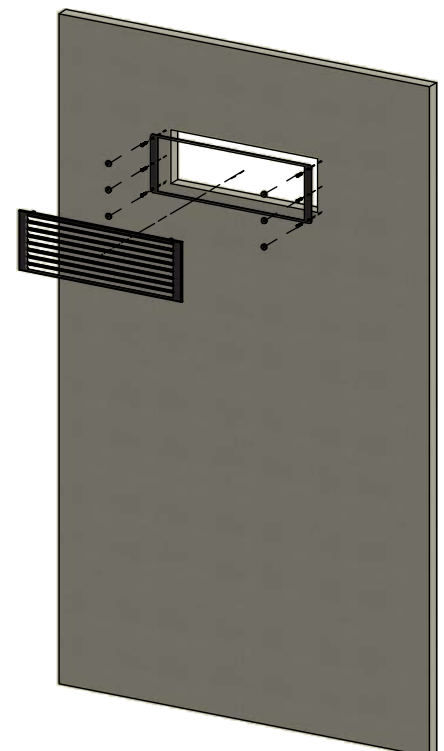

INSTRUCTIONS FOR USE

BAFFLE PLATES

The baffle plates are located in the upper part of the combustion chamber. The plates holds back smoke, making sure it stays inside the combustion chamber for a longer time before escaping through the chimney. This reduces the flue gas temperature as the gases have more time to dissipate heat to the stove.

The baffle plates must be removed for sweeping; see "Maintenance". Note that the baffle plates are made of porous, ceramic material, and are liable to break easily. You should therefore handle them with care.

The baffle plates are subject to wear and tear and not covered by the warranty.

COMBUSTION AIR

Combustion air is pre-heated and fed indirectly to the fire. The combustion air flow determines the heat output from your built-in stove. At the same time, the air flow cleans the glass pane to prevent build-up of soot. If there is a soot formation on the glass, this is often due to the fact that the combustion air is turned too much down.

When lighting the fire, the combustion air should be fully open.

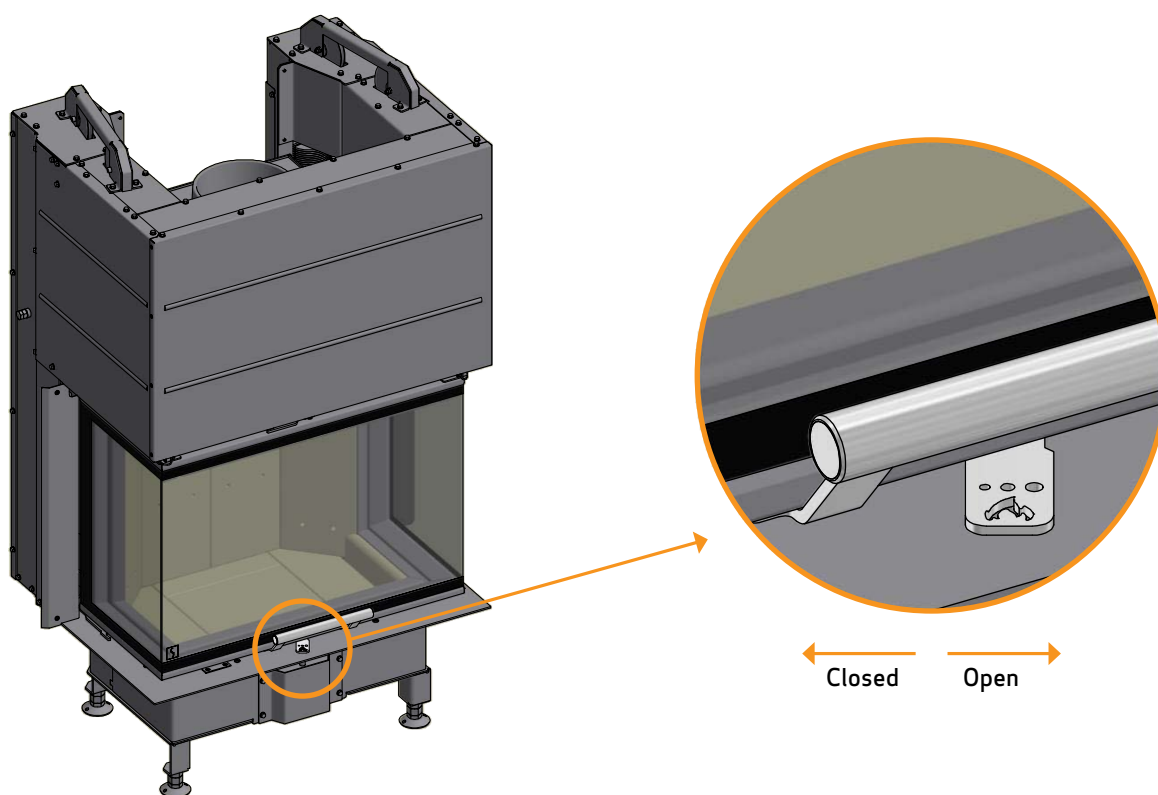

INSTRUCTIONS FOR HEATING

ENVIRONMENTALLY FRIENDLY OPERATION

Avoid turning down your wood-burning stove to the point where no flames are visible from the wood, as this leads to poor combustion and low efficiency. The gases released from the wood will not be burnt off due to the low temperature in the combustion chamber. Some of the gases will condense in the stove and flue system as soot, and this could lead to your chimney catching fire at a later point. The residual smoke which exits the chimney will pollute the surrounding area and cause an unpleasant smell.

NOTE!

No matter how good your chimney is, it will not perform well, if you do not use it correctly. Equally, a poor chimney may well give you acceptable results, if you use it correctly

LIGHTING

We recommend the use of fire lighters, or similar products, which are available from your Scan dealer. Using fire lighters helps light the wood more quickly and keeps the combustion process clean.

See our video about correct firing on www.scan.dk or scan the QR-code. Please note that this video is only intended as a guide. You should also follow the instructions in the specific manual for your stove model!

Scan the QR-code and see our video about correct firing.



NOTE: Never use liquid lighting fuels!

"TOP DOWN" LIGHTING

"Top down" lighting is a more environmentally friendly way of lighting the fire and helps to keep the glass area as clean as possible.

Do as follows for a correct "top down" lighting:

- 4 pieces of wood approx. 25-30 cm long with a weight of approx. 0.4-0.6 kg per piece.
- 12-20 thin pieces of firewood of about 25-30 cm in length, with a total weight of approx. 1 kg.
- 3-4 fire lighters

- 1 Place the pieces of wood, firewood and fire lighters in the combustion chamber as shown below
- 2 Set the combustion air control to maximum for 20-30 minutes (See "Instructions for use")
- 3 When the large pieces of wood have caught fire, you can adjust the combustion air to the desired level

NOTE: The wood must not cover the bottom entirely and must never be placed higher than the indication for max. load (This does not apply at a cold start) (See Maintenance).



Place the fire lighters
between the upper sticks

USING THE STOVE IN VARIOUS WEATHER CONDITIONS

The way the wind affects the chimney can have a big impact on how your stove reacts under various wind loads; you may need to adjust the airflow to achieve good combustion. Fitting a damper in the flue pipe may also help, as it will allow you to regulate the draught under changing wind loads.

Fog and mist can also have a big impact on chimney draught; you may need to use other settings for the combustion air to achieve good combustion.

CONTINUOUS OPERATION

It is important to obtain as high a temperature as possible in the combustion chamber. This results in best possible use of the stove and fuel, as well as achieving clean combustion. In this way you will avoid build-up of soot on the combustion chamber lining and glass pane. During operation, you should not see any smoke; just a movement in the air that indicates combustion is in progress.

- After completing the lighting phase, you should have a good layer of embers in the stove; you can then start operation of it properly
- Add 3-4 pieces of wood at a time: they should be about 0,5-0,7 kg in weight and about 30-40 cm long

NOTE: The wood must catch fire quickly. This is why we recommend setting the combustion air flow fully open. Operating the stove at too low a temperature and with too little the combustion air can lead to gases igniting, which can damage the stove.

- When adding wood, always open the glass door carefully to prevent smoke escaping
- Never add wood, while the fire is burning nicely

WARNING ABOUT OVER-FIRING

If the stove is continuously fired with larger amounts of wood than recommended and/or receives too much air, this can cause a heavy heat development liable to damage both stove and the surrounding walls. We therefore recommend that you always observe the max. recommended amount of fuel (See under "Technical Data").

FIRING IN THE SPRING OR AUTUMN

In the spring/autumn transition period, where there is less need for heating, we recommend you light the stove "top down" once, perhaps adding just two pieces of wood to ensure that the combustion chamber lining burns clean again.

GENERAL NOTES

PLEASE NOTE! Parts of the wood-burning stove, especially the outer surfaces, become hot during use. Due care should be exercised.

- Never empty ashes into a flammable container. Ashes can contain glowing embers long after you finish operating the stove.
- When the stove is not in use you can close the dampers to avoid a draught through the stove.
- If the stove has not been used for some time, you should check the flue passageways for potential blockages before relighting.

NOTE: Never place flammable material in the radiation zone of the stove!

THE FUNCTION OF THE CHIMNEY

The chimney is the wood-burning stove's motor; its performance determines how well your stove will work. The draught in the chimney creates negative pressure in the wood-burning stove. The negative pressure draws the smoke out of the stove and takes in air through the combustion air damper to fuel the combustion process. Combustion air is also used for the airwash system that keeps the glass clear of soot.

The draught in the chimney is created by the difference in temperature inside and outside the chimney. The higher the difference in temperature, the better the draught. This is why it is important that the chimney reaches operating temperature before you reduce the damper settings to restrict combustion in the stove (a brickwork chimney will take longer to reach operating temperature than a steel chimney). It is very important that the operating temperature is reached as quickly as possible on days when the draught in the chimney is poor due to unfavourable wind and weather conditions.

You need to get a few flames going as quickly as possible. Chop the wood extra thin; use an extra fire lighter etc.

- After longer periods without use, you must check the chimney flue for blockages.
- You can connect several units to the same chimney. You should however first check the relevant regulations in this respect.

CHIMNEY FIRE

In the event of a chimney fire, keep the stove door, ash drawer, and all dampers on the stove closed. In an emergency, call the fire service.

- We recommend that you get a chimney sweep to check the chimney before using the stove again.

HANDLING OF THE FUEL

SELECTING WOOD/FUEL

You can use any type of wood as fuel. However harder woods, such as beech or ash, are generally better for heating, as they burn more evenly and create less ash. Other woods, such as maple, birch and spruce, are excellent alternatives.

PREPARATION

The best fuel is obtained where the tree has been felled and the wood sawn and split before May 1st. Remember to cut the wood to match the size of the combustion chamber. We recommend a diameter of 6-10 cm. The length should be about 6 cm shorter than that of the combustion chamber to leave enough space for air to circulate. If the diameter of the wood is greater than the above, it should be split down its length. Wood that has been split dries faster.

STORING

You need to store the sawn and split wood in a dry place for 1-2 years before it will be dry enough to burn. Wood dries faster if you stack it in an airy place. Before using it, it is a good idea to store the wood for a few days at room temperature. Remember that wood absorbs moisture from the air during autumn and winter.

MOISTURE

To avoid problematic impact on the environment and to ensure optimum operating economy, the wood should be perfectly dry before it can be used as fuel. If you use wood that is too damp, most of the heat it produces will be used up in evaporating the water. The stove will accordingly not increase in temperature, nor emit heat to the room as a result. This is obviously poor economy, and it will cause soot build-up on the glass pane, in the stove and in the chimney. Operation using moist wood also pollutes the environment.

- Maximum wood moisture content should not exceed 20%. A moisture content of 15-18% will deliver best efficiency.
- An easy way of checking wood moisture content is to knock the ends of the two pieces of wood together. If the wood is moist, the sound will be slightly muffled.

USE OF THE FOLLOWING AS FUEL IS ILLEGAL

NOTE: It is absolutely prohibited to fire with painted, pressure impregnated or glued wood, or sea driftwood.

NOTE: Nor should you ever burn chipboard, plastics, or treated paper. These contain substances that are hazardous to human health, to the environment, your stove, and your chimney.

In short - make sure you only use proper wood.

CALORIFIC VALUE OF THE WOOD

The various woods have different calorific values. In other words, for certain species of wood, you will need to use a greater quantity to achieve the same heating performance. This Instruction Manual assumes that you will be using beech, which has a very high calorific value and is also the easiest wood to get hold on.

If you use oak or beech as fuel, you need to bear in mind that these wood types have a greater calorific value than for example birch. To avoid any risk of damage to the stove, you should therefore make sure to use less fuel in these cases.

Wood types	kg Drywood/m ³	Compared to beech
Hornbeam	640	110%
Beech/Oak	580	100%
Ash	570	98%
Maple	540	93%
Birch	510	88%
Pine	480	83%
Fir	390	67%
Poplar	380	65%

MAINTENANCE

SWEEPING THE CHIMNEY AND CLEANING THE STOVE

Follow national and local regulations for sweeping the chimney. We recommend having the stove cleaned regularly by a chimney sweep.

Before cleaning the stove and sweeping the chimney, the baffle plates must be removed.

NOTE: All service and repair must be done, when the stove is cold.

CHECKING THE STOVE

Scan A/S recommends that you check your stove thoroughly after sweeping/cleaning. Check all visible surfaces for cracks. Check that all joints are tight and that the gaskets are correctly seated. Worn or deformed gaskets should be replaced.

SERVICING

We recommend that the stove is thoroughly serviced at least every two years by a qualified fitter. Remember only to use original spare parts.

The service should include the following:

- Lubricate hinges using copper grease.
- Check the gaskets. Replace any that are broken or have turned hard.
- Check the combustion chamber lining and the grate.
- Check heat-insulating materials.

COMBUSTION CHAMBER LINING

The combustion chamber lining is not covered by the warranty.

The lining consists of the following parts:

- 13 chamotte plates (1-3) ■ 2 baffle plates (5 & 7) ■ 2 fittings for baffle plates (4 & 6)

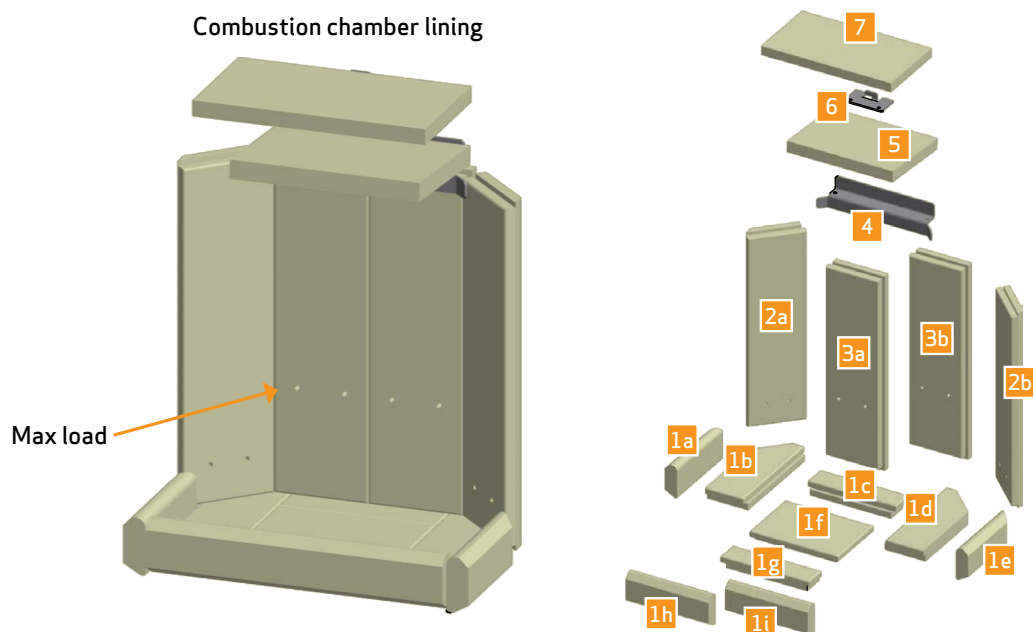

REPLACEMENT OF THE COMBUSTION CHAMBER LINING

Place the chamotte plate #1 in the bottom.
Then place chamotte plate #2a and #2b

1

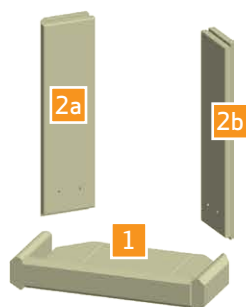

Place the chamotte plates #3a and #3b

2

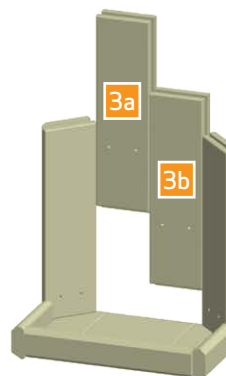

Place baffle fitting #4 and the upper baffle plate #7

3

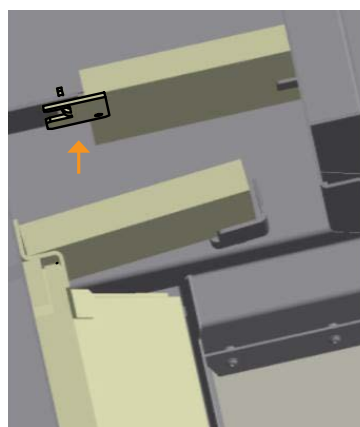

Place baffle fitting #6 on the edge of the chamotte plates #3a and #3b. Then place the lower baffle plate #5. Make sure that the two baffle plates are placed identically

4

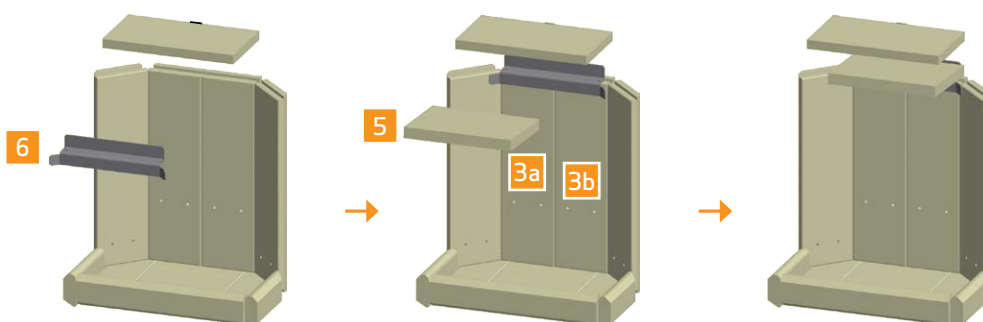

GASKETS

All stoves have seals made of ceramic material fitted to the stove, the door and/or the glass. These seals are subject to wear and tear and must be replaced when necessary.

Gaskets are not covered by the warranty.

PAINTED SURFACES

Clean your built-in stove by wiping it down with a dry, lint-free cloth.

DISPOSAL OF STOVE PARTS

Steel/cast iron	Send for recycling
Glass	Dispose of as ceramic waste
Combustion chamber lining	Vermiculite and chamotte are not recyclable. Dispose of as waste
Baffle plates	Vermiculite and chamotte are not recyclable. Dispose of as waste
Gaskets	Dispose of as waste

CLEANING THE GLASS

Our stoves are designed to prevent serious soot build-up on the glass. The best way to achieve this is to make sure you have a good supply of combustion air. It is also very important that the wood is dry and the chimney correctly dimensioned.

Even if you operate the stove in accordance with our instructions, a slight film of soot may still accumulate on the glass. You can easily remove this film by wiping the glass down with a dry cloth and then with a cloth dampened with glass cleaner.

- Please note that the glass cleaner is not to get into contact with the gaskets, as this can discolour the glass permanently.
- The glass cleaner must not come into contact with the painted surfaces, as these can be damaged.

In order to be able to clean the glass on the inside, you must first pull out the glass frame.

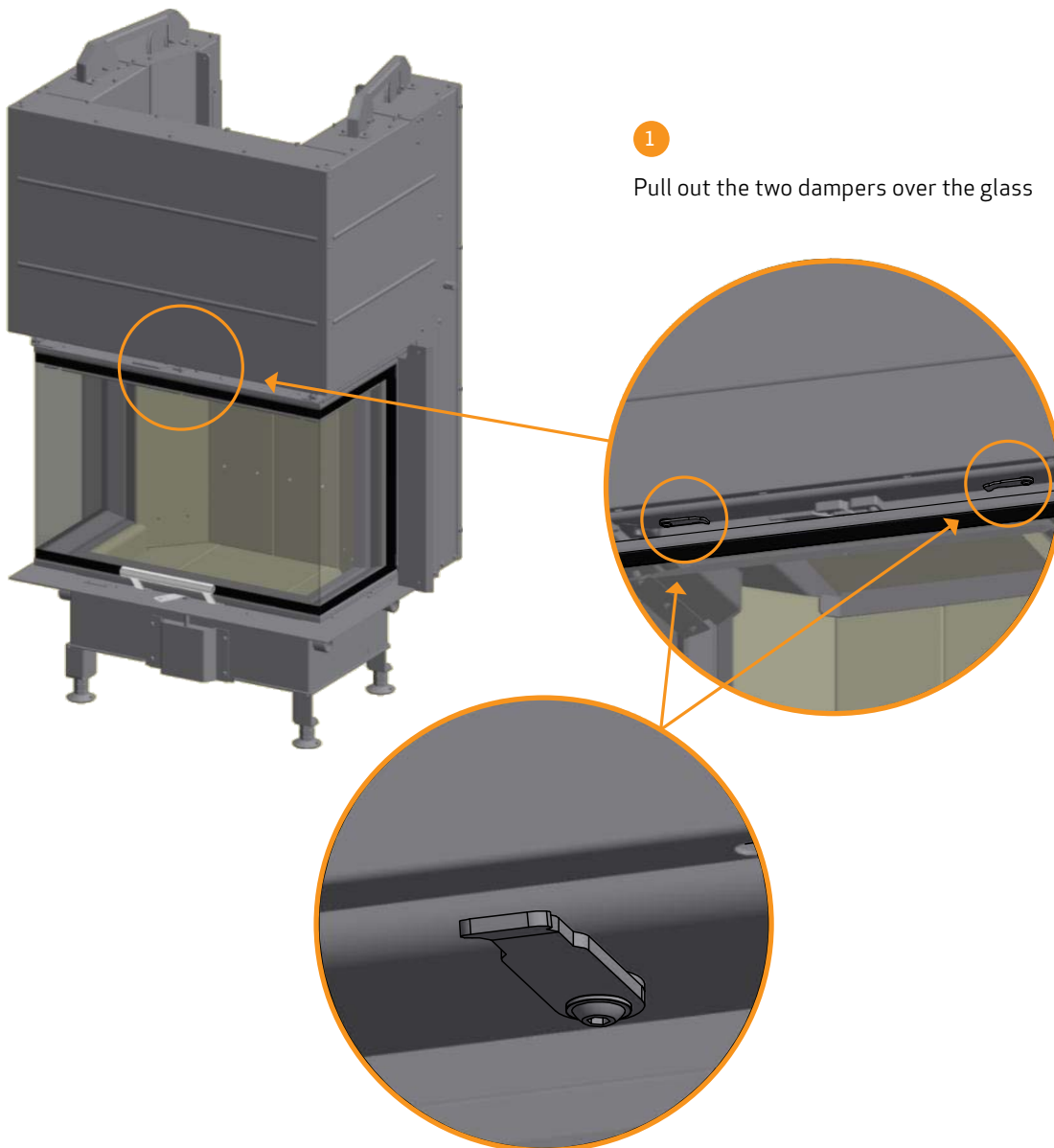

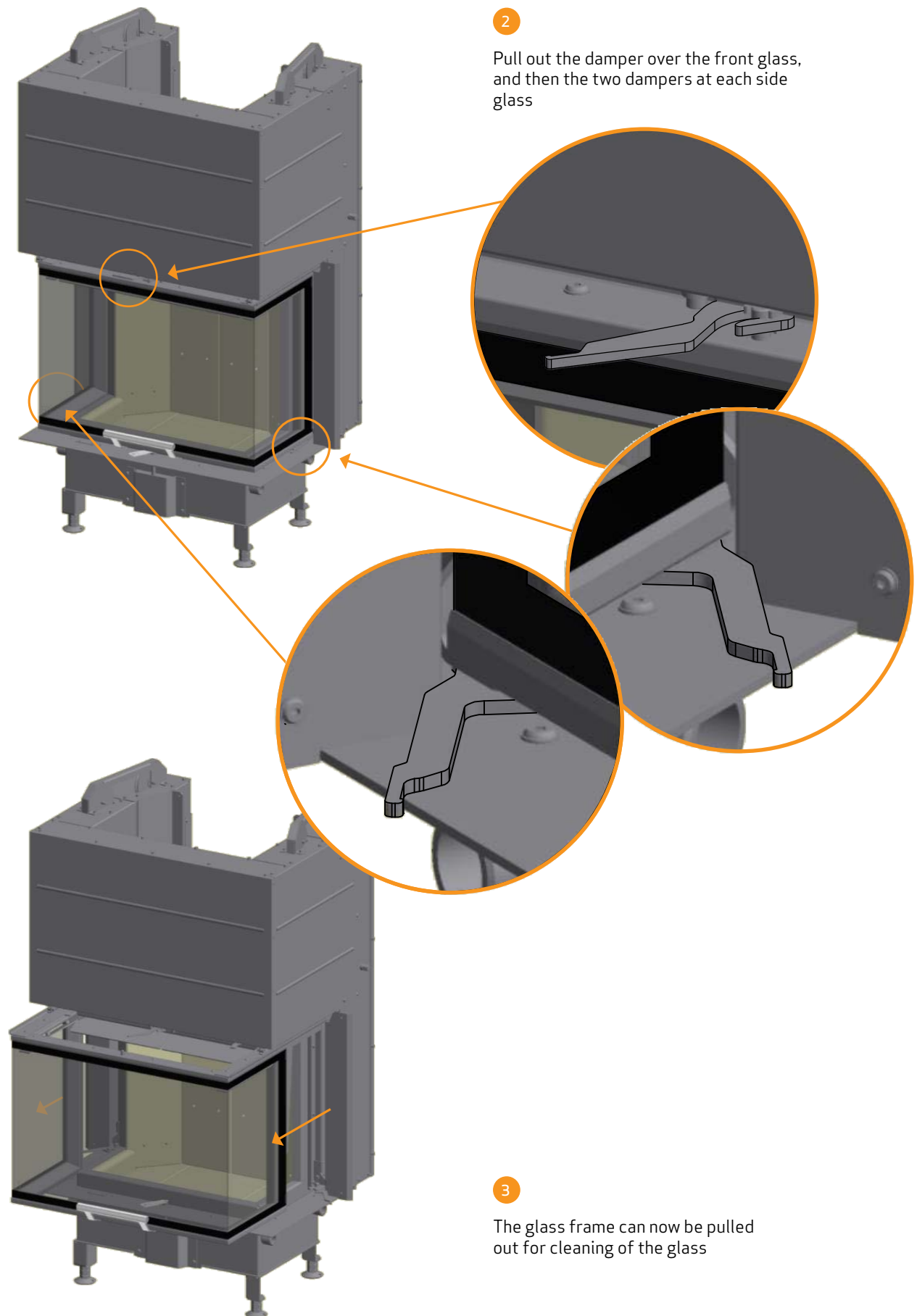

TROUBLESHOOTING

SMOKE ESCAPING

- Damp wood
- Chimney is not properly dimensioned for the built-in stove
- Is the chimney the right height for its surroundings?
- At rear outlet, check that the flue pipe does not obstruct the chimney draught
- Chimney not drawing properly
- Check if the smoke gas pipe/chimney are blocked
- Vacuum in the room
- The door is opened before the embers have burned down sufficiently

WOOD BURNING TOO QUICKLY

- The air valves are set incorrectly
- Inferior firewood (wast wood, pallets etc.)
- The baffle plate is incorrectly mounted or missing
- Too much chimney draught

SOOT BUILD-UP ON GLASS

- Incorrect secondary airflow setting
- Damp wood
- Inferior firewood (waste wood, pallets etc.)
- Excessive primary air
- Wood pieces too large for lighting
- Chimney not drawing sufficiently

WHITE SHADOW ON THE INSIDE OF THE GLASS

- Over-firing (See "Instructions for heating")
- Vacuum in the room
- Too much primary air

EXCESSIVE SOOT BUILD-UP IN CHIMNEY

- Poor burning (more air is required)
- Damp wood

THE SURFACE OF THE BUILT-IN STOVE IS TURNING GREY

- Over-firing (See "Instructions for heating")

POOR HEATING PERFORMANCE OF BUILT-IN STOVE

- Damp wood
- Inferior wood quality with low calorific value
- Not enough wood
- The baffle plates are not fitted correctly

SMELL AND SOUND OF THE BUILT-IN STOVE

- The lacquer on the built-in stove hardens, when you use the built-in stove for the first time; this can cause an odour. Open a window or a door for ventilation and make sure that the built-in stove is heated up sufficiently to avoid odours later.
- When heating up and cooling down, the built-in stove may make some clicking noises. These are due to the huge temperature differences to which the material is exposed and do not indicate any product defects.

WARRANTY

All wood-fired Scan products are made of high-quality materials and subject to strict quality controls before leaving the factory. We give a warranty of 5 years on manufacturing errors or defects.

You must quote your stove's product registration number when you contact us or your authorised Scan dealer with a warranty claim.

The warranty covers all parts which in the opinion of Scan A/S require repair or replacement due to manufacturing or construction error

The warranty applies to the original purchaser of the product only, and is not transferable (except on prior sale).

The warranty covers only damage caused by manufacturing or construction errors.

THE FOLLOWING PARTS ARE NOT COVERED BY THE WARRANTY

- Wear and tear parts, such as the combustion chamber liners, baffle plates, riddling grate, glass, and seals (except for defects which were present on delivery).
- Defects caused by external chemical and physical influences during transportation, storage and assembly, or at a later time.
- Soot build-up caused by poor chimney draught, damp wood, or improper use.
- Costs of additional heating in connection with a repair.
- Transport costs.
- Costs for setting up or removing the wood stove.

THIS WARRANTY IS VOID

- In case of incorrect installation (the installer is responsible for observing and complying with legal requirements and local bylaws, along with this Assembly- and Instructionsmanual for the wood-burning stove and accessories).
- In case of improper use, and/or use of prohibited fuels, non-original spares (see this Assembly- and instructions manual).
- If the product registration number of the stove has been removed or damaged.
- In case of repairs that do not comply with our instructions or instructions by an authorised Scan dealer.
- In case of any manipulation of the original state of this Scan product or its accessories.
- This warranty is only valid in the country to which this Scan product was originally supplied.

Product registration number

Quote this number at all enquiries